

**IMPORTANT:
THESE INSTRUCTIONS ARE TO REMAIN
WITH THE HOMEOWNER**

These instructions are supplementary to the Installation and Operating Instructions supplied with the fireplace and should be kept together. Refer to the Installation and Operating Instructions for proper gas supply, safety requirements and operating instructions.

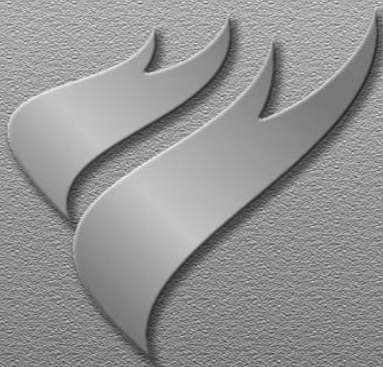

TOWN & COUNTRY
L U X U R Y F I R E P L A C E S

**TCWS.54NG03C2
BLACK DIAMOND
BURNER KIT
INSTRUCTIONS**



**PART# TCWS.54NG03C2
For Model: TCWS54
Series: C2**

Contents of Package

2 BURNER ASSEMBLIES

1 BURNER TRAY

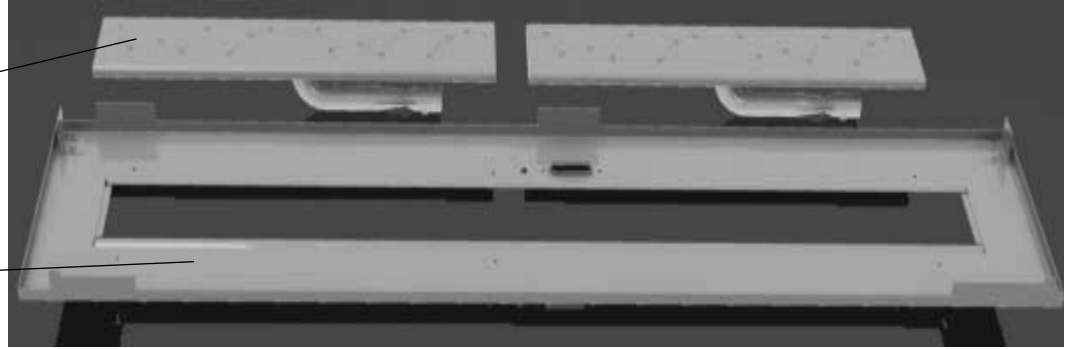

1 INSTRUCTION PACK

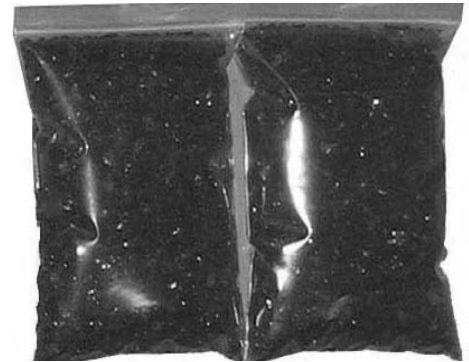

2 5 LB GLASS MEDIA

Black Diamond Burner Installation

If converting to propane see conversion instructions on page #5 before proceeding.

Install panels according to the TCWS.54CE2 Installation and Operating manual prior to burner installation. (Page 23)

1. Install the right burner by laying into location trough and sliding to the right to engage the venturi tube over the orifice. Repeat with left burner. (Fig. #1)

NOTE: check air shutter for correct fuel setting before proceeding further. Both burner shutters are to be set the same, fully closed for natural gas. 13/64 (0.2)" open for LP.

CAUTION: The burners should be tightly butted up against each other at the center to ensure correct operation.

2. Tilt the burner tray into the unit and place on top of the manifold brackets (Fig. #2). Attach pilot to burner tray. Be sure pilot is attached to burner support rail with screw in first hole position. (Fig. #2a)

FIRST HOLE POSITION

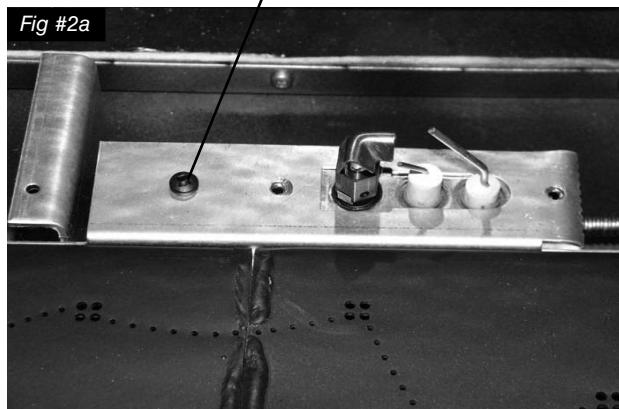

3. Secure the burner tray to manifold brackets using eight screws (Fig. #3).

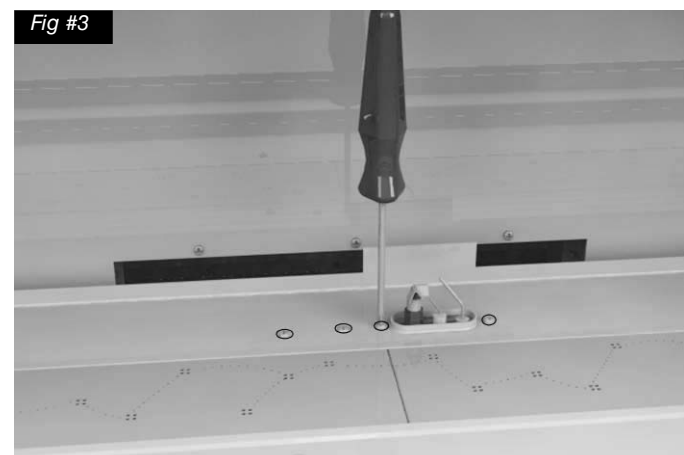
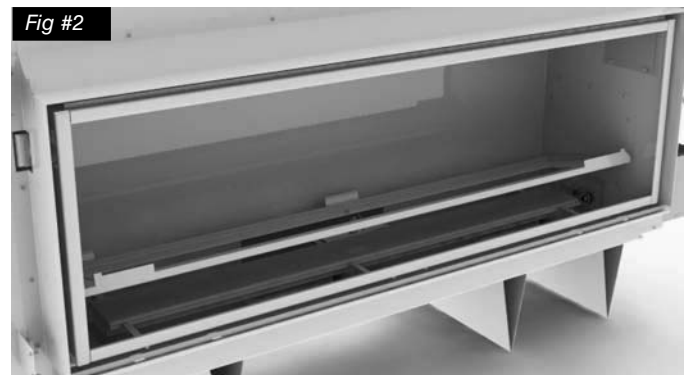
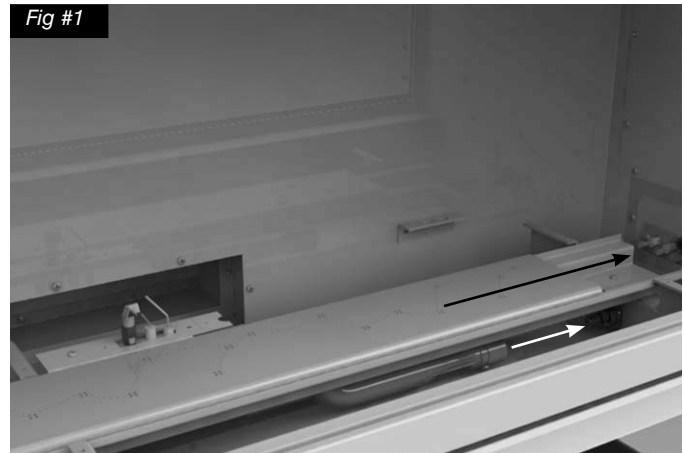

- Place glass media into the burner tray and brush smooth so that a very light layer covers the burners. (Fig. #4)

NOTE: Too much glass media will cause sooting and improper flame pattern.



- Place rear porcelain trim, wide edge, against the back panel and press down over the pre-bent tabs on the burner tray. (Fig. #5)



- Place the front porcelain trim so that it rests on the front shelf of the firebox and is snug against the firebox frame. Ensure that the wide edge of the trim is against the firebox frame. (Fig. #6 & 7)

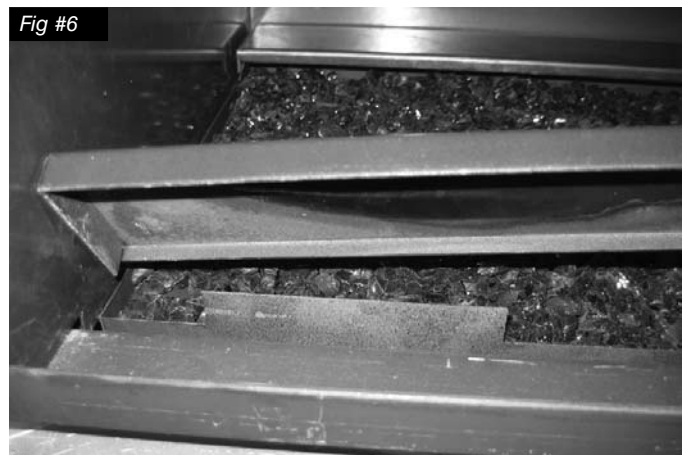

WIDE EDGE TO FRONT OF FIREPLACE WITH FRONT TRIM, TO THE REAR OF THE FIREBOX FOR REAR TRIM.



Propane Conversion

If the unit is to be used on propane convert as follows using the components supplied with this burner:

CAUTION

The gas supply and electrical power shall be shut off before proceeding with the conversion.

Note: Factory supplied components must be used to ensure correct input. After conversion confirm proper manifold pressure.

WARNING

This conversion kit shall be installed by a qualified service agency in accordance with the manufacturer's instructions and all applicable codes and requirements of the authority having jurisdiction.



If the information in these instructions is not followed exactly, a fire, explosion or production of carbon monoxide may result causing property damage, personal injury or loss of life.

The qualified service agency is responsible for the proper installation of this kit.

The installation is not proper and complete until the operation of the converted appliance is checked as specified in the manufacturer's instructions supplied with the kit.

Fig #8a

PROPANE CONVERSION KIT

		Kit # TCWS.54LPC03/ESB/ESC for use with model: Pour utiliser avec du modèle: TCWS.54CE2
Date: _____		
By / Par: _____		
LP GAS/ DU GAZ LP		This appliance was converted to PROPANE GAS with this kit on this date by the organization which accepts the responsibility that this conversion has been properly made. / Cet appareil etait converti au gaz LP par l'emploi de la troussé de conversion par une organisation qui accepte la responsabilité pour une installation en bon état.
12.5 in/wc / 12.5 po/c.e. (3.11 kPa)		
13.9 in/wc / 13.9 po/c.e. (3.45 kPa)		
11.0 in/wc / 11.0 po/c.e. (2.74 kPa)		
1.65 mm		
Max.: 54,900 (16.1) Min.: 46,200 (13.5)		010610 6-WSS4 5052.52088

CONVERSION LABEL (5052.52088)

MINIMUM RATE SCREW (5005.16)



MAIN BURNER (1.65mm) ORIFICES (5022.86)

1. If installed remove the glass media from the burners.
2. If installed remove the burner tray from the manifold brackets. (Fig. #8b)
3. Remove LP burners
4. Using a 1/2" wrench, undo the natural gas burner orifice, (marked 764). Apply a small amount of pipe joint compound to the threads of the propane burner orifice (marked 165) to ensure a good seal, before screwing it into the fitting.

Loosen the primary air shutter screw, open shutter to give a gap of 13/64" (0.2") and re-tighten. Repeat on other burner. (Fig. #10)

↓
13/64
↑

Fig #8b



Fig #9



Fig #10



Fig #11



5. With a 7/16" wrench loosen the pilot head on the pilot assembly. (Fig. #11)

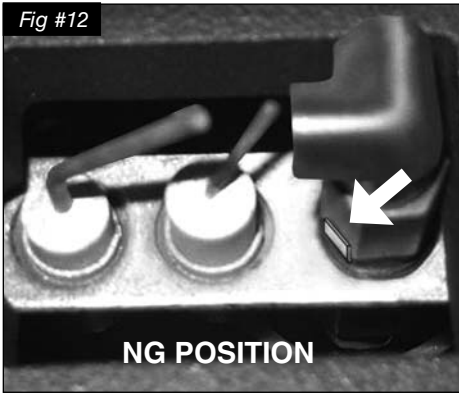

- Slide the pilot adjustment band over and ensure that the hole in the orifice band is showing.

◀ Fig. #12 shows NG position
 Fig. #13 shows LP position). ▶

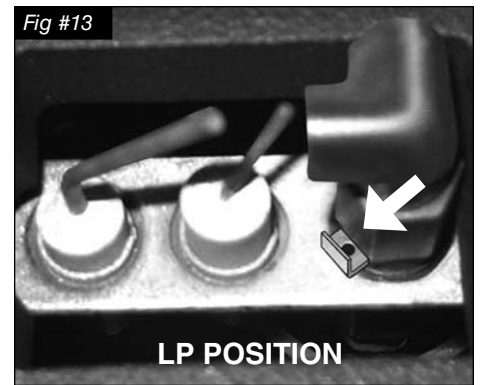

- Remove the access panel, 10 screws, and set aside.



- Lift the control box shield and rest on the edge of the screw above the access hole (Fig. #14)

CONTROL BOX SHIELD



- Remove the minimum rate screw located in the valve. (Fig. #15)

The minimum rate screw is sealed with an O-ring. Use a thin bladed screwdriver to back the screw out past the limit of the threading. At this point a groove on the screw body will be visible just above the valve body. Insert a thin tool (knife blade or fine screwdriver blade) into the groove and gently pry the screw up. It helps to rotate the screw while lifting on it.

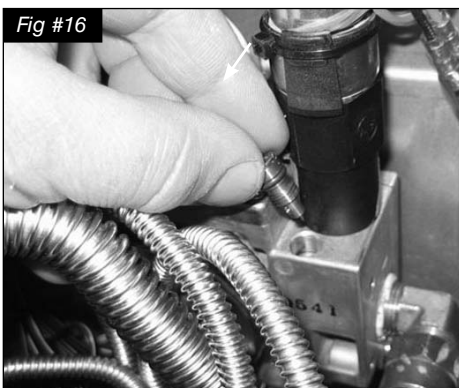



- Replace the minimum rate screw with the one provided in the propane conversion kit supplied with this fireplace. Ensure that the screw is fully seated. (Fig. #16)

- Remove the aluminum cap from the top of the pressure regulator. (Fig. #17)



ADD DATE ADD NAME

Fig #18

 Kit # TCWS.54LPC03/ESB/ESC for use with model: Pour utilise avec du modèle:	
Date:	TCWS.54CE2
By / Par:	
LP GAS/ DU GAZ LP 12.5 in/wc / 12.5 po/c.e. (3.11 kPa) 13.9 in/wc / 13.9 po/c.e. (3.45 kPa) 11.0 in/wc / 11.0 po/c.e. (2.74 kPa) 1.65 mm Max.: 54,900 (16.1) Min.: 46,200 (13.5)	This appliance was converted to PROPANE GAS with this kit on this date by the organization which accepts the responsibility that this conversion has been properly made. / Cet appareil etait convertir au gaz LP par l'emploi de la trousses de conversion par une organization qui accepte la responsabilité pour une installation en bon état.
010610 6-WS54 5052.52088	

- Press down on the center post and rotate 90°. The center post should stay down. (Fig. #19). Replace the aluminum cap.
- Fill in the date and the name of the person who performed the conversion in the white area on the conversion label. (Fig #18). Peel off the protective backing and apply the conversion label directly over the gas specifications on the rating label.

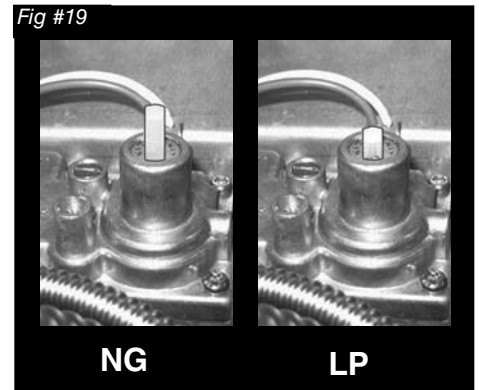

CONTROL SHIELD SHOWN IN PROPER CLOSED POSITION

- Re-locate the control box shield and re-attach the access panel to the side of the firebox with the screws previously removed. (Fig. #20 & 21)
- If the burner was removed in previous steps replace in reverse order or return to installation process on Pg. 3.

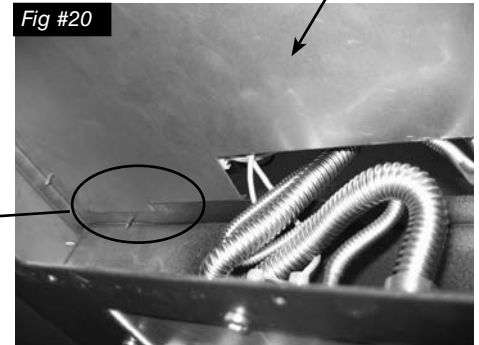

WARNING: Both the control box shield and the access panel must be reinstalled after conversion/ installation or servicing has been completed. Failure to do so will cause overheating and premature failure of the control system.

Gas Pressure Check

Note: To test the gas pressure, turn off the gas supply before removing the plug from the supply pressure test port or manifold pressure test port.

Verify gas pressures with the fireplace lit and on the highest setting.

Fig #23



1. Remove the plug from the pressure test port using a 3/16" hex key. The plug is located between the right side lintel and firebox side. (Fig. #23)

Fig #22

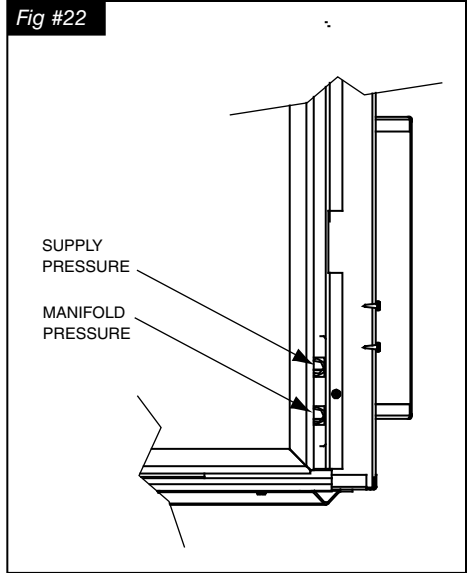

Fig #24



2. Thread the extension test fitting into the open port. (Fig. #24)
3. Attach a pressure gauge onto the fitting.
4. When testing is complete shut off the gas, remove the fitting and replace the plug. Thread sealant will be required to ensure a gas tight connection.

Correct gas pressure requirement:

Supply Pressure	Natural Gas	Propane
Min. Pressure <small>(For purpose of input adjustment)</small>	5.0" WC	12.5" WC
Max. Pressure	13.9" WC	13.9" WC
Manifold Pressure		
Maximum	3.8" WC	11" WC
Minimum	2.1" WC	5.5" WC

Burner Flame Adjustment

The air shutter on the burner tube controls the primary combustion air. It is set to the closed position at the factory for natural gas fuel. For LP see Pg.5. Some adjustment may be necessary to obtain desired flame and to eliminate carbon deposits. Evaluate flame appearance after the fireplace has reached operating temperature. See Fig. #25 for proper flame pattern.

Open primary air if the window glass and firebox have carbon accumulation and/or the flames are long, dark and stringy. The shutter may also be opened to lessen the flame height.

NOTE:

Proper air shutter setting is required.

The flame should be just orange and “lazy”. It should NEVER be set to create sooting on internal parts and window glass. Allow the fireplace to run for 30 minutes before evaluating flame appearance.

Fig #25



Replacement Parts

(WHEN ORDERING, INCLUDE PART NUMBER WITH DESCRIPTION)

ITEM	DESCRIPTION	PART NO.
------------	-------------------	----------

#1.....	BLACK DIAMOND BURNER	TCWS.54NG03C2
---------	----------------------------	---------------

* #2.....	GLASS MEDIA (2 required).....	TCRP.501201
-----------	-------------------------------	-------------

* NOT SHOWN

①

KIT CONTENTS:

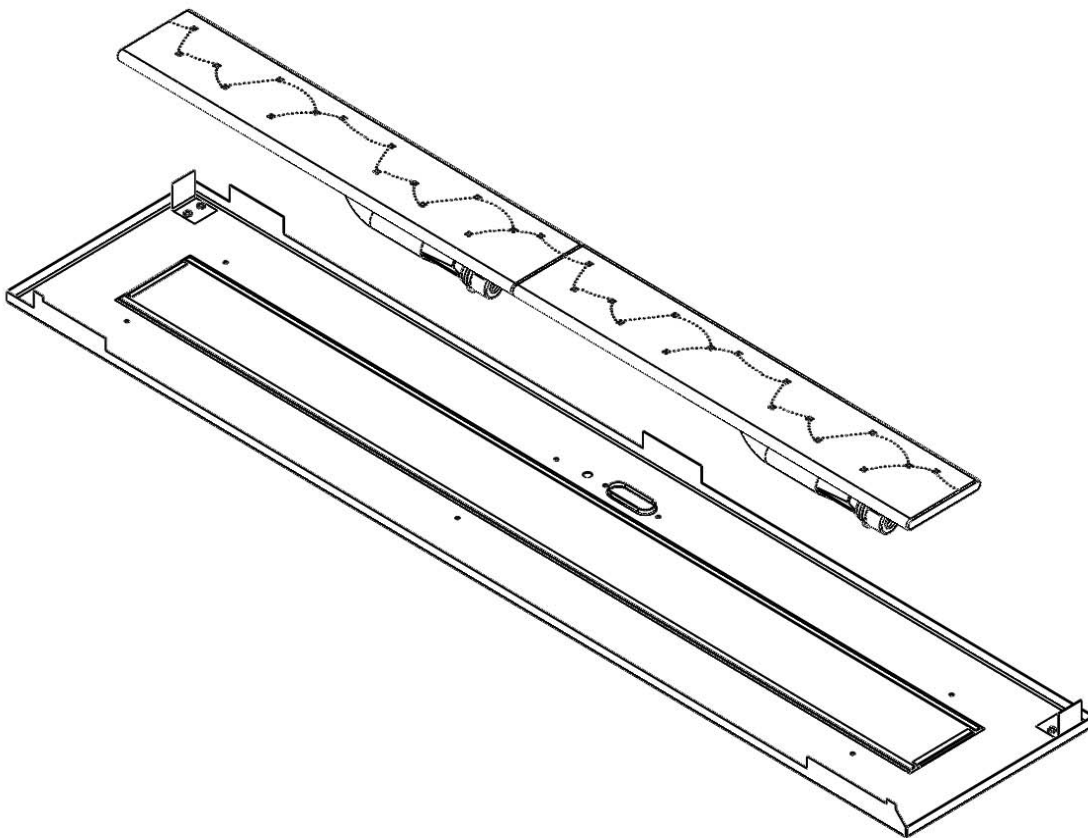



TOWN & COUNTRY
L U X U R Y F I R E P L A C E S

Technical support: 1-250-748-1184
Web site: www.townandcountryfireplaces.net
2975 Allenby Rd., Duncan, BC V9L 6V8