

**INSTALLER: Leave this manual with the appliance.
CONSUMER: Retain this manual for future reference.**

These instructions are supplementary to the Installation and Operating Instructions supplied with the fireplace and should be kept together. Refer to the Installation and Operating Instructions for proper gas supply, safety requirements and operating instructions



TOWN & COUNTRY
L U X U R Y F I R E P L A C E S

**TC36 See-Thru
BLACK DIAMOND
BURNER KIT**



**PART#22150024
For TC36 SEE-THRU
FIREPLACES
Series D/D2**



Package Contents

1 BURNER TUBE.....	TC36.50118398
1 SHUTTER CONTROL ROD.....	5002.1752
1 BURNER TRAY ASSEMBLY.....	TC36.9690
2 BURNER SHIELD, FRONT/REAR.....	TC36.9693PBK
1 LEFT BURNER SHIELD.....	TC36.9693.2PBK
1 RIGHT BURNER SHIELD.....	TC36.9693.5PBK
1 LINE COVER.....	TC36.9699PBKA
1 PILOT SHIELD.....	TC36.9626PBK
1 MANIFOLD ASSEMBLY.....	TC36.9692
2 MEDIA SPACER, FRONT/REAR.....	9695
1 MEDIA SPACER, CENTER.....	9694
1 TUMBLED GLASS MEDIA.....	5012.01
1 HARDWARE PACKAGE.....	TC36.STHK03
1 PILOT ASSEMBLY.....	5005.025
1 1/4" FLEX COMPRESSION.....	5019.225
1 1/2" FLEX FLARE CONNECTION.....	5019.223

Fig. # 1

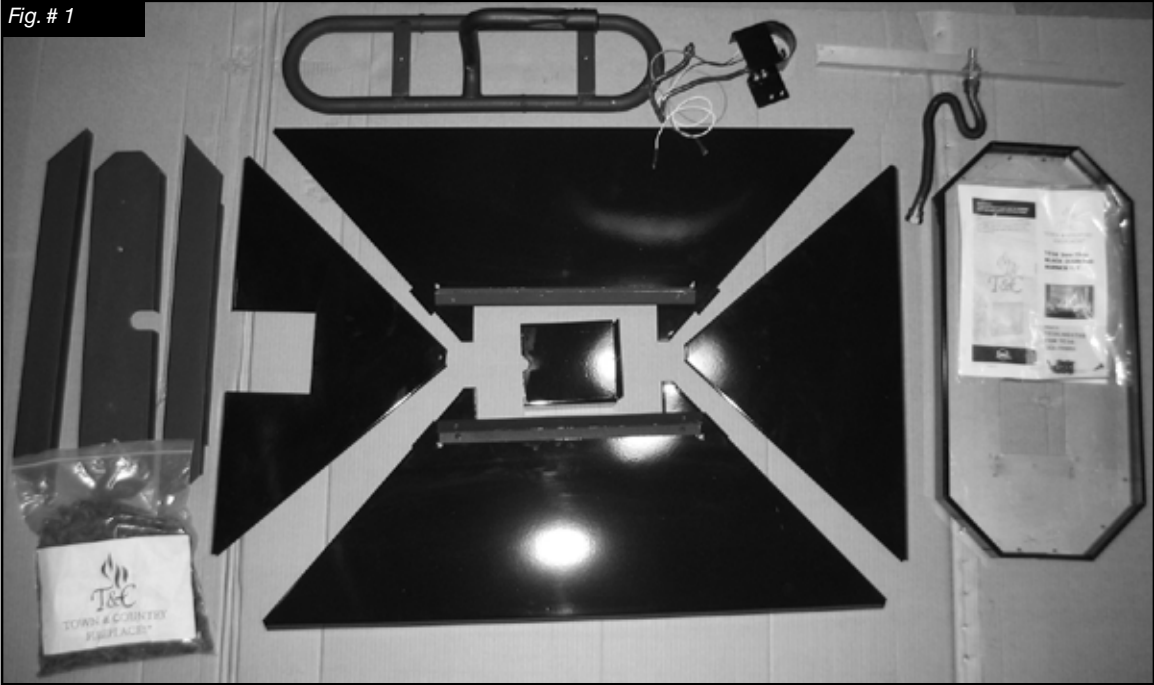

Black Diamond Burner Installation

NOTE: For the purposes of these instructions the controls and gas connections are on the right hand side of the unit.

Remove porcelain panels if they are installed.

1. Remove the panel retainer clip located on the upper heat shield, install the left panel securing with panel retainer clip previously removed.
(Fig. #2)



2. Attach the manifold assembly to the floor of the firebox using two screws. Seal the remaining holes in the floor of the fireplace with screws.
(Fig. #3).

3. Connect the manifold flex gas line and pilot flex gas line to the bulkhead ensuring a gas-tight connection.

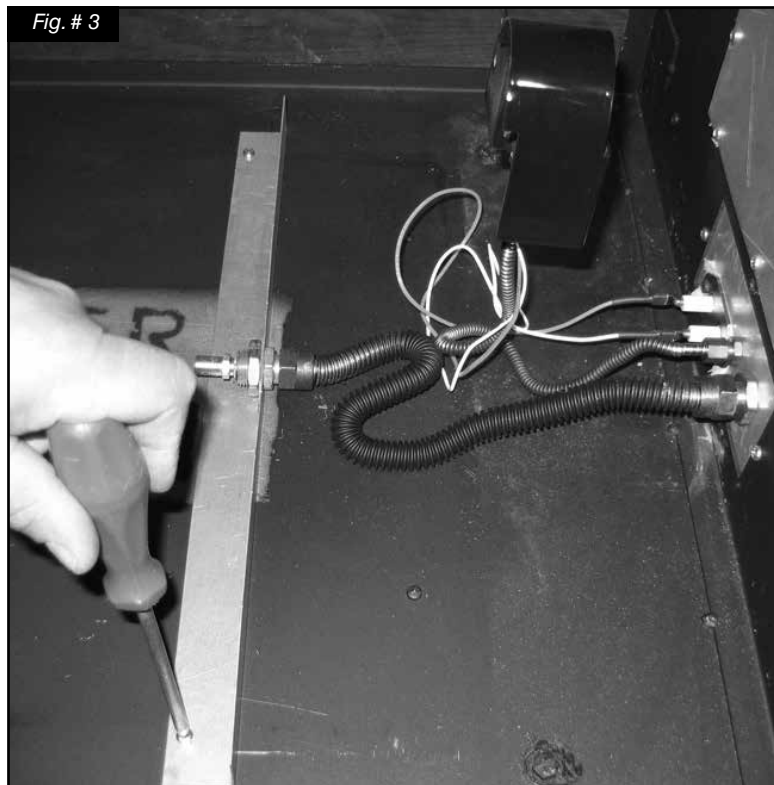

- Secure the electrical bulkhead plate (Fig.#4) and gasket to the firebox. (2 screws) Attach the ignition and sensor wires to the module. (Fig.#5).

NOTE: If converting to propane refer to the propane conversion section before continuing. Pg. 12

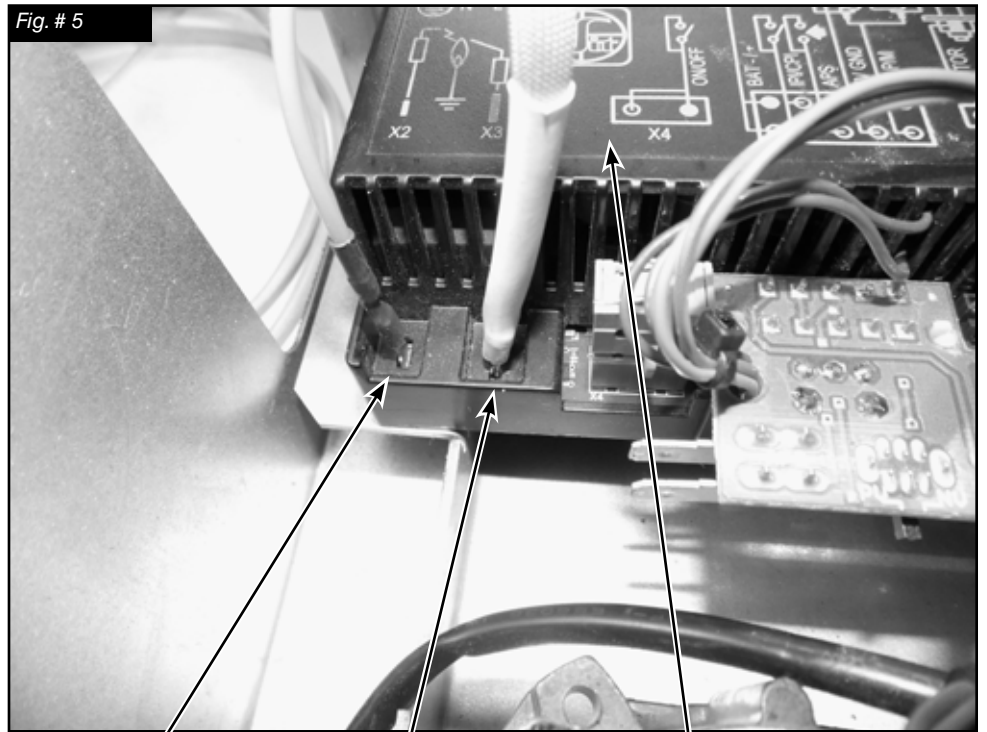
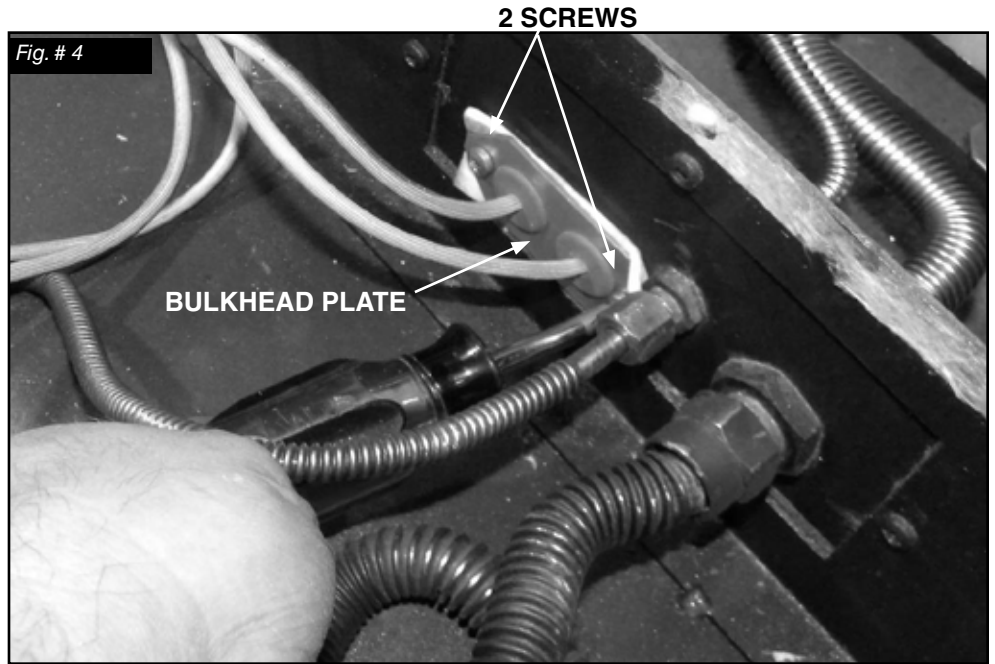

IGNITION WIRE (RED)

FLAME SENSOR WIRE (WHITE)

INTERFACE MODULE

5. Attach the inlet cover using the top screw of the bulkhead (Fig. #6). Install the right porcelain panel (as in Fig. #2).

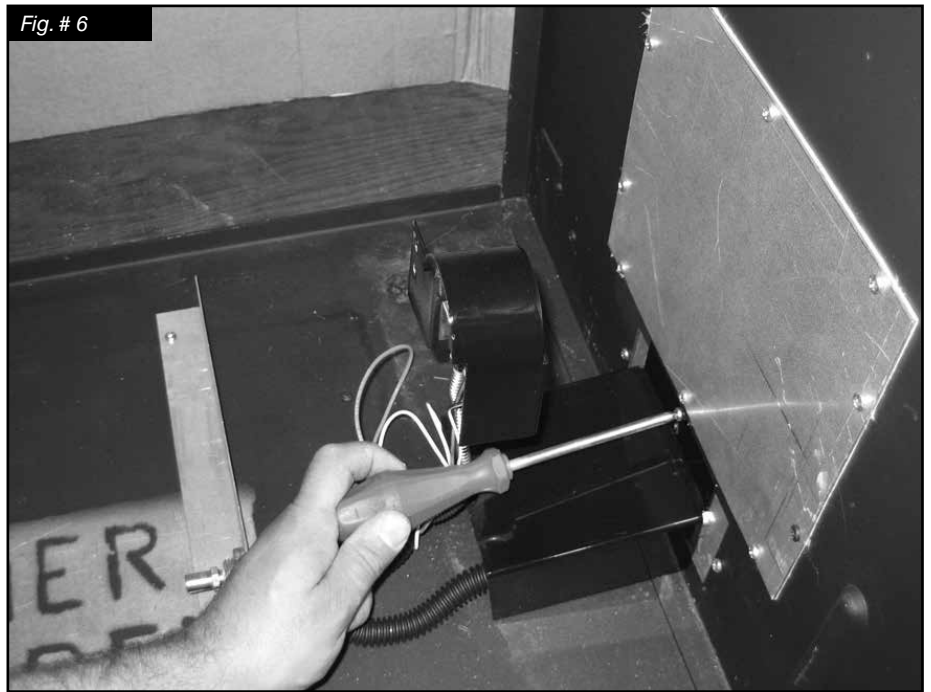

6. Position the right burner shield over the inlet cover ensuring that the pilot assembly is protruding through the half-hole between the inlet cover and the right burner shield (Fig. #7).



7. While supporting the right burner shield install the rear burner shield, resting the edge of the right burner shield onto the support tab of the rear burner shield (Fig. #8).

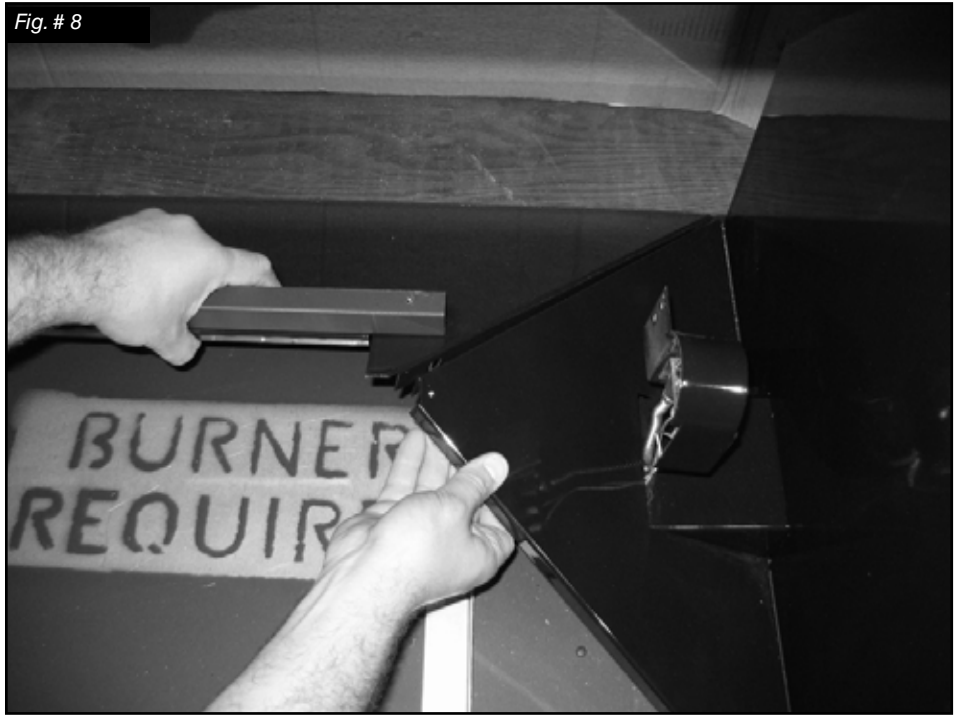

8. Install the front burner shield positioning the support tab under the right burner shield (Fig. #9).



9. Install the left burner shield. This will be a snug fit requiring some alignment (Fig. #10).



10. Position the burner tray assembly on top of the assembled shields and attach it using four screws (Fig. #11).

NOTE: Ensure that the square access hole of the tray is positioned to the right (control side).

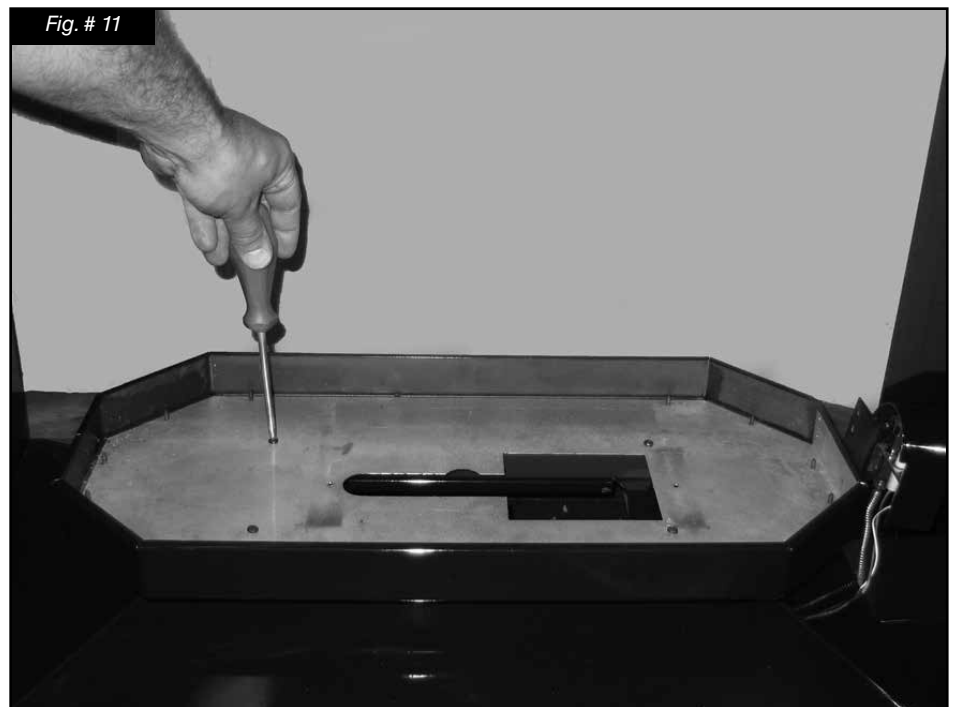

11. Attach the pilot assembly to burner tray using two screws (Fig. #12).

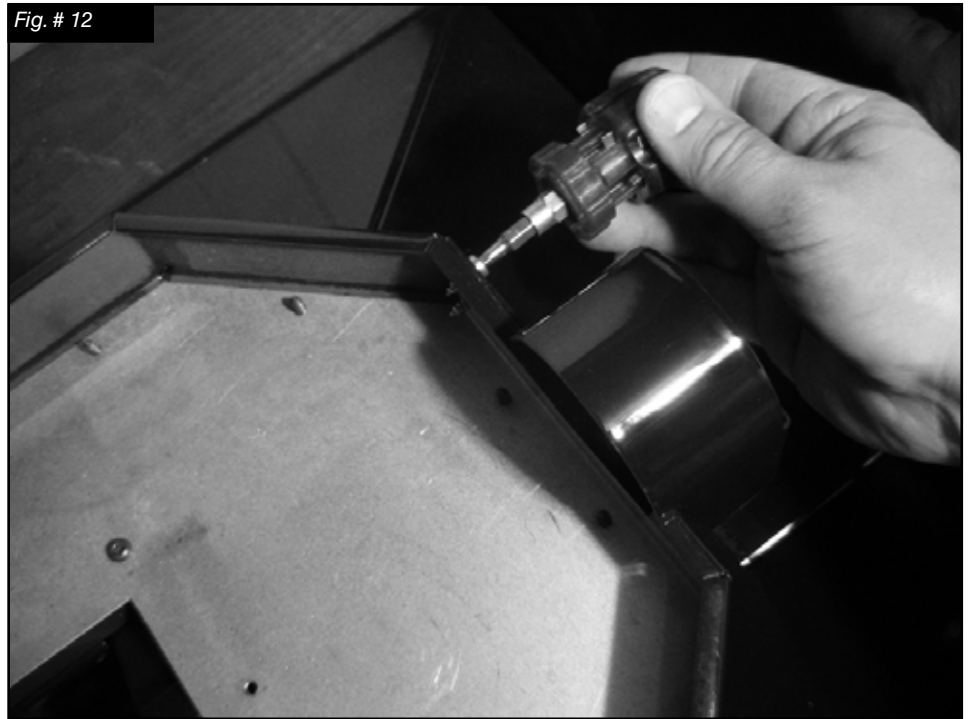

12. Position a front/rear media spacer at the rear of the burner tray (Fig. #13).

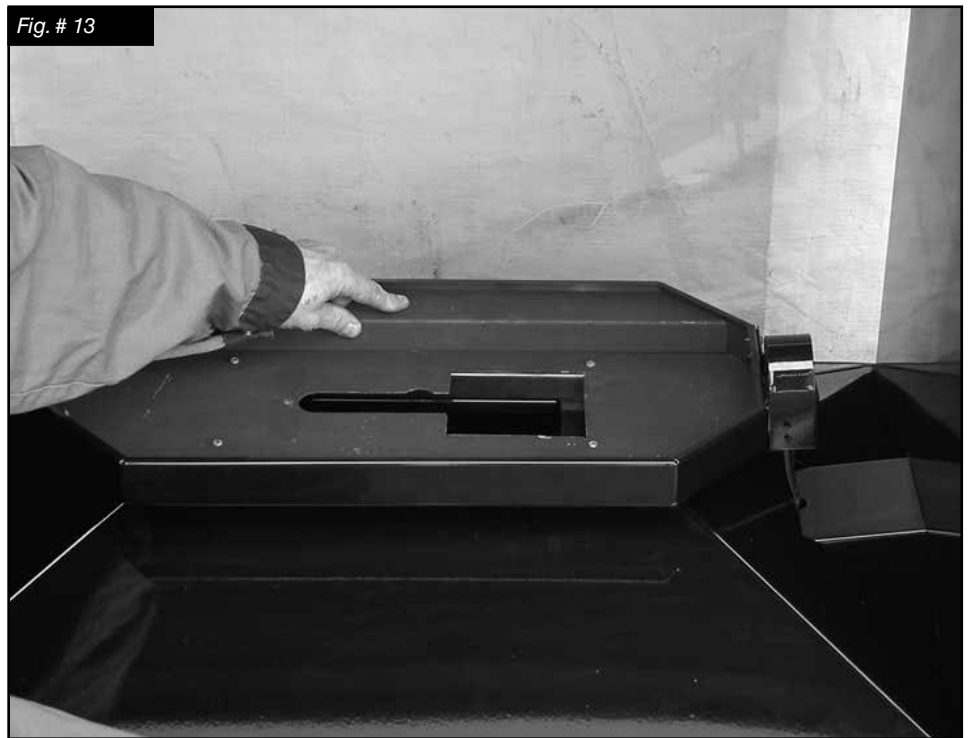

13. Position the other at the front of the tray (Fig. #14).



14. Loosen the screw on the burner tube shutter enough to allow smooth movement from open to closed positions (visible in Fig. #16).
15. Install the burner tube by tipping the inlet into the slot in the bottom of the burner tray (Fig. #15).



6. Hold the burner tube in a position so that the shutter control rod can be inserted into the shutter tab (Fig. #16) after passing through the rod hole in the top right corner of the front burner shield. (See Fig. #28).

Fig. # 16



17. Set the burner tube into place ensuring that it slips over the orifice on the manifold assembly. Align the attachment holes line up with the holes in the tray.

NOTE: Shutter must be fully open for propane or fully closed for natural gas (push down on the shutter control rod to open, pull up to close). Some adjustment may be required (see page 17).

18. Position the center media spacer on the inside of the burner tube and attach using two long screws (Fig. #17).

Fig. # 17

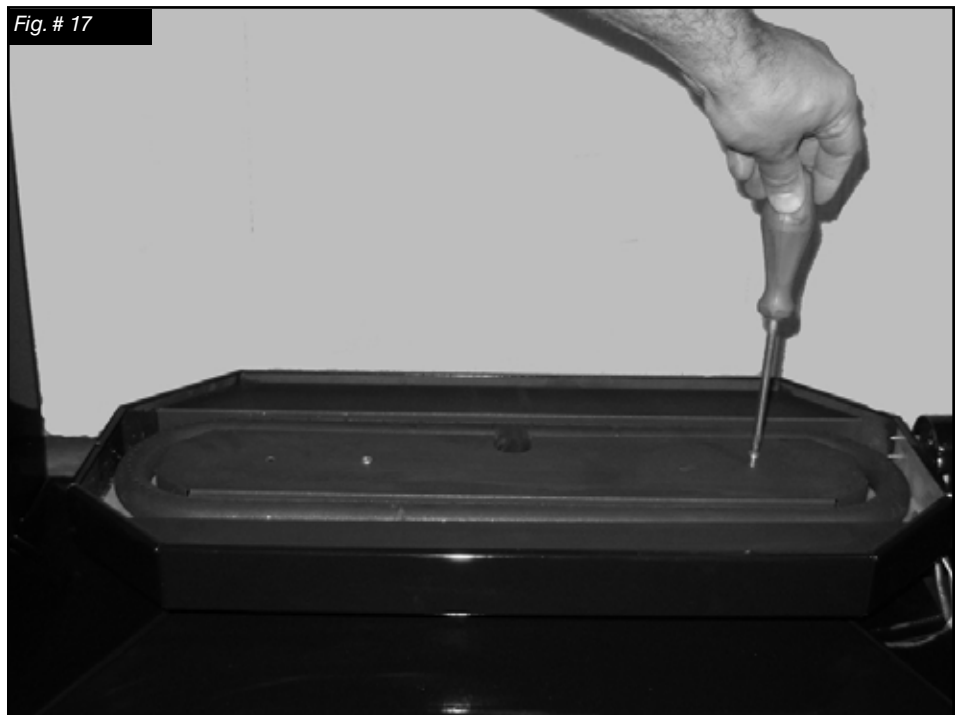

19. Empty the contents of the supplied tumbled glass bag onto the burner tray (Fig. #18) and spread the glass evenly over top of the tube and media spacers (Fig. #19).

NOTE: Too much tumbled glass over the burner will cause sooting.

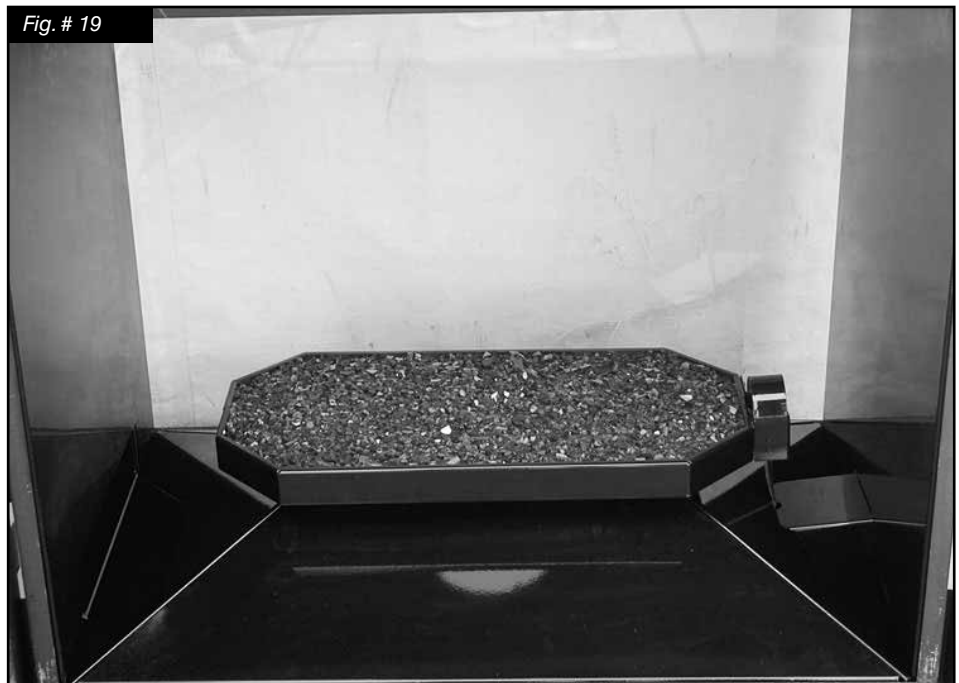

Propane Conversion

WARNING

This conversion kit shall be installed by a qualified service agency in accordance with the manufacturer's instructions and all applicable codes and requirements of the authority having jurisdiction.

If the information in these instructions is not followed exactly, a fire, explosion or production of carbon monoxide may result causing property damage, personal injury or loss of life.

The qualified service agency is responsible for the proper installation of this kit. The installation is not proper and complete until the operation of the converted appliance is checked as specified in the manufacturer's instructions supplied with the kit.

CAUTION

The gas supply and electrical power shall be shut off before proceeding with the conversion.

If the unit is to be used on propane convert as follows using the components supplied with this fireplace:

	This kit for use with model: / TC36STNG03.D
	Pour utiliser avec du modèle: / TC36STNG04.D
Date:	TC42
By / Par:	Series D
PACIFIC ENERGY	
LP GAS/ DU GAZ LP	
12.5 in/wc / 12.5 po/c.e. (3.11 kPa)	This appliance was converted to PROPANE GAS with this kit on this date by the organization which accepts the responsibility that this conversion has been properly made. / Cet appareil est converti au gaz LP par l'emploi de la trousse de conversion par une organisation qui accepte la responsabilité pour une installation en bon état.
13.9 in/wc / 13.9 po/c.e. (3.45 kPa)	
10.0 in/wc / 10.0 po/c.e. (2.49 kPa)	
2.50 mm	
Max.: 61,000Btu (17.8kw)	081014 6-TC36ST_D 5052.5206D
Min.: 47,000Btu (13.7kw)	

CONVERSION LABEL (5052.5206D)

Note:

Factory supplied components must be used to ensure correct input. After conversion confirm proper manifold pressure.

1. Ensure the burner, pilot and gas supply are turned off, and the appliance has cooled.
2. Using a 1/2" wrench, undo the natural gas burner orifice, (marked #25). (Fig. #20)
3. Apply a small amount of pipe joint compound to the threads of the propane burner orifice (marked 2.50) to ensure a good seal, before screwing it into the fitting.
4. Open primary air shutter fully.
5. With a 7/16" wrench loosen the pilot head on the pilot assembly (Fig. #21)



- Slide the pilot adjustment band over and ensure that the hole in the orifice band is showing. (Fig. #23 indicates NG position, Fig. #24 indicates LP position)

Fig #23

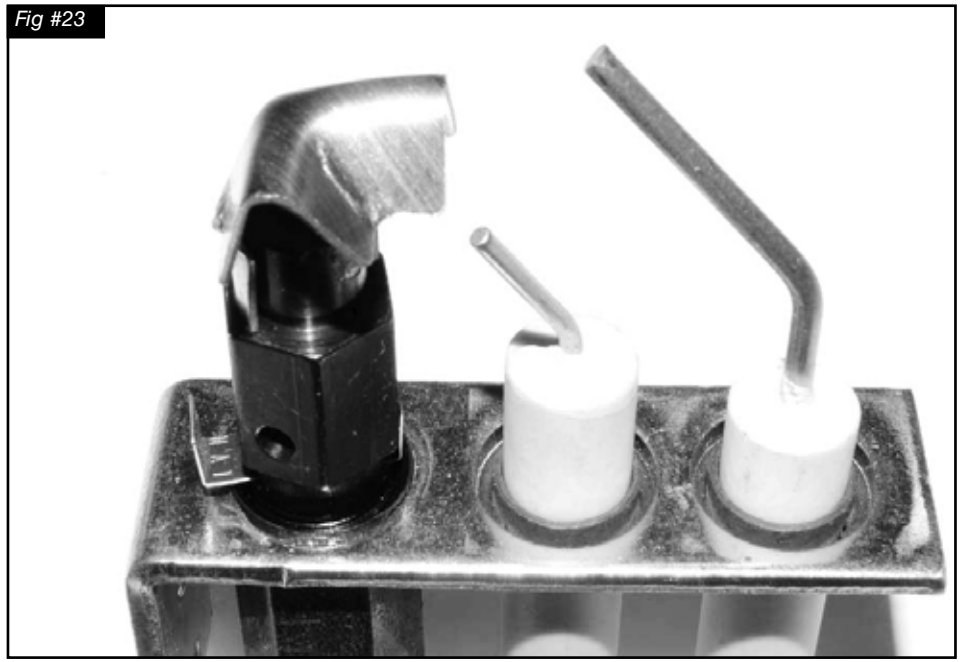

- Remove access panel, 10 screws, and set aside. (Fig. #22)

Fig #24

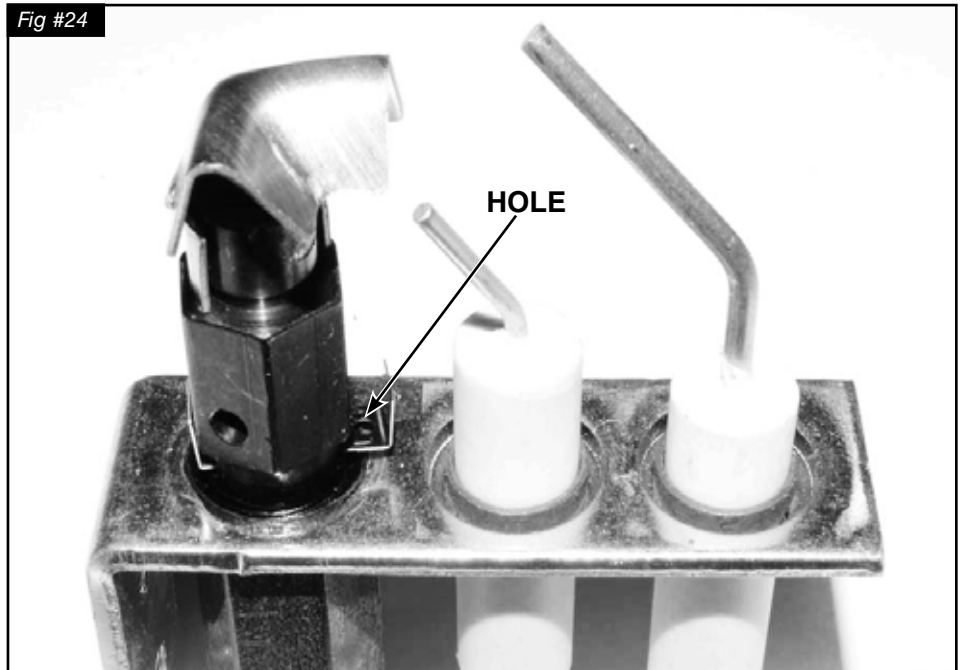

- 12) Fill in the date and the name of the person who performed the conversion in the white area on the conversion label. Peel off the protective backing and apply the conversion label directly over the gas specifications on the rating label.
- 13) Attach the access panel to the side of the firebox with the previously removed screws.

Note: Gasket must be installed with access panel.

ADD NAME ADD DATE

This appliance was converted to propane gas

PACIFIC ENERGY

Kit Number

5052.52001-B

dd mm yy

Company

Address

The above accepts the responsibility that this conversion has been properly performed.

Firme

a m j

Numero d'assemblage

5052.52001-B

PACIFIC ENERGY

Cet appareil a été converti en gaz propane

Gas Pressure Check



Note: To test the gas pressure, turn off the gas supply before removing the blanking plug from the pressure test port. Verify gas pressures with the fireplace lit and on the highest setting.

- 1) Remove the blanking plug from the pressure test port. The plug is located between the right side intel and firebox side. (Fig. #25)

CORRECT GAS PRESSURE REQUIREMENT:

Supply Pressure (For purpose of input adjustment)	Natural Gas	Propane
Minimum	5.0" wc	12.5" wc
Maximum	13.9" wc	13.9" wc

Manifold pressure

Maximum	3.5" wc	10.0" wc
Minimum	1.6" wc	6.4" wc

- 2) Thread the extension test fitting into the open port. (Fig. #26)
- 3) Attach a pressure gauge onto the fitting.
- 4) When testing is complete shut of the gas, remove the fitting and replace the plug. Thread sealant will be required to ensure a gas tight connection.



Burner Flame Adjustment

The air shutter on the burner tube controls the primary combustion air. It is set to the closed position at the factory for natural gas fuel. Some adjustment may be necessary to obtain desired flame and to eliminate carbon deposits. Evaluate flame appearance after the fireplace has reached operating temperature. See Fig. #27 for proper flame pattern. Open primary air if the window glass and firebox have carbon accumulation and/or the flames are long, dark and stringy. The shutter may also be opened to lessen the flame height.

CAUTION:

**Burner area may be hot!
Turn off the fireplace and
allow the unit to cool before
proceeding.**

To adjust: (See Fig. #28)

Push the shutter control rod to increase the amount of primary air to create a more blue flame. Pull the shutter to decrease the amount of primary air to create a more yellow flame.

NOTE:

Proper air shutter setting is required.

The flame should be just orange and “lazy”. It should NEVER be set to create sooting on internal parts and window glass.

Fig #27



Fig #28



Replacement Parts

NOTE: FIREPLACE & VALVE REPLACEMENT PARTS ARE LOCATED IN THE APPLIANCE INSTRUCTIONS

ITEM... DESCRIPTION PART NO.

- 1..... MEDIA SPACER, CENTER.....9694
- 2..... BURNER TUBE TC36.50118398
- 3..... MEDIA SPACER, FRONT/REAR.....9695
- 4..... TRAY TRIM.....9690.5
- 5..... PILOT ASSEMBLYTCRP.5005025
- 6..... PILOT SHIELD9626.002
- 7..... LINE COVER TC36.9699PBKA
- 8..... BURNER SHIELD, RIGHT.....9693.5
- 9..... BURNER SHIELD, FRONT/REAR9693
- 10.....FITTING, ORIFICE IN 5019.21

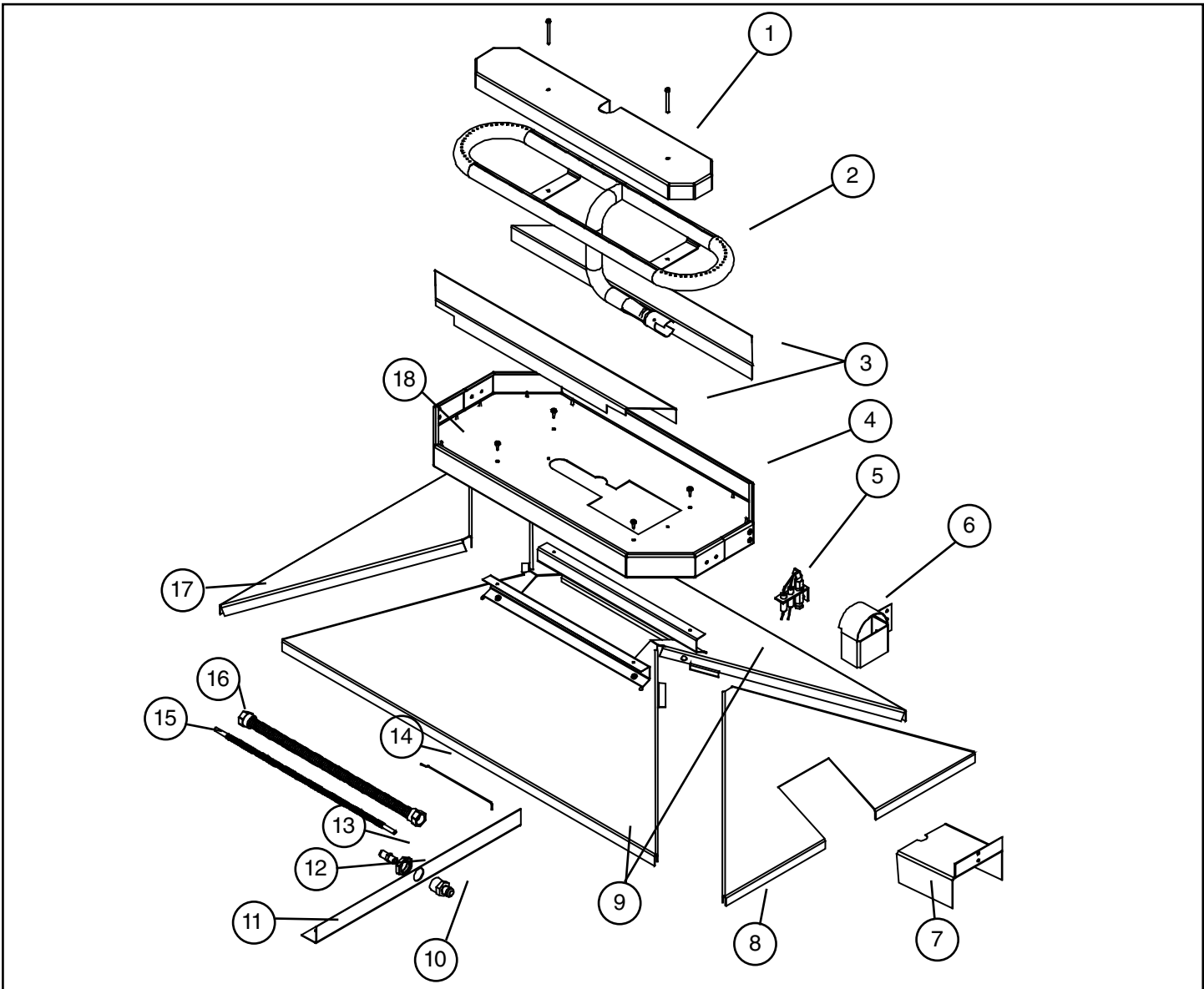





Reproduction, adaptation, or translation
without prior written permission is prohibited,
except as allowed under the copyright laws.



For technical support, please contact your retailer.

**www.townandcountryfireplaces.net
2975 Allenby Rd., Duncan, BC V9L 6V8**