

**INSTALLER: Leave this manual with the appliance.
CONSUMER: Retain this manual for future reference.**

These instructions are supplementary to the Installation and Operating Instructions supplied with the fireplace and should be kept together. Refer to the Installation and Operating Instructions for proper gas supply, safety requirements and operating instructions.

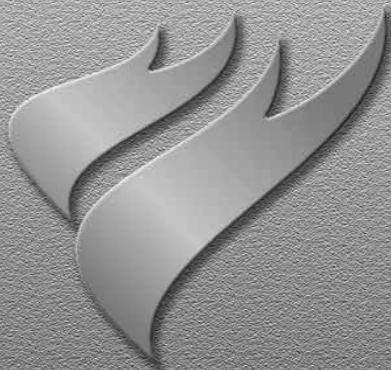

TOWN & COUNTRY
LUXURY FIREPLACES

TC54 BLACK DIAMOND BURNER KIT INSTRUCTIONS



**SKU# 22150048
For TC54 Series D
Fireplaces**



Package Contents

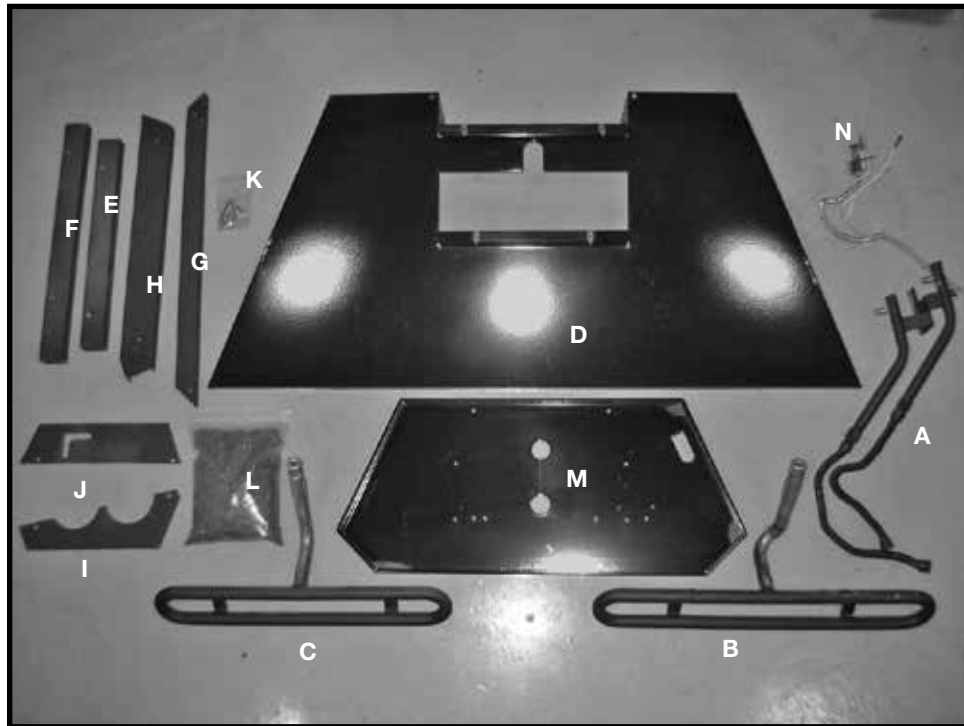

Figure 1: TC54 Black Diamond burner kit contents.

- A** MANIFOLD ASSEMBLY
(Including supply tube)
- B** BURNER TUBE, FRONT
- C** BURNER TUBE, REAR
- D** BURNER SHIELD
- E** MEDIA SPACER, Rr Center
- F** MEDIA SPACER, Fr Center
- G** MEDIA SPACER, Front
- H** MEDIA SPACER, Rear
- I** MEDIA SPACER, Left
- J** MEDIA SPACER, Right
- K** HARDWARE PACKAGE
- L** 5 lbs. GLASS MEDIA
- M** BURNER TRAY
- N** PILOT

Black Diamond Burner Installation

NOTE:

If unit is to be converted to Propane, see Propane conversion instructions on page 13 before proceeding.

The panel set instructions must be used when installing this burner. Typically all panels except the right side should be installed prior to burner installation.

NOTE: Plug the 4 vacant holes in the bottom of the firebox with #8x1/2" screws.
The holes are not required for this style of burner.

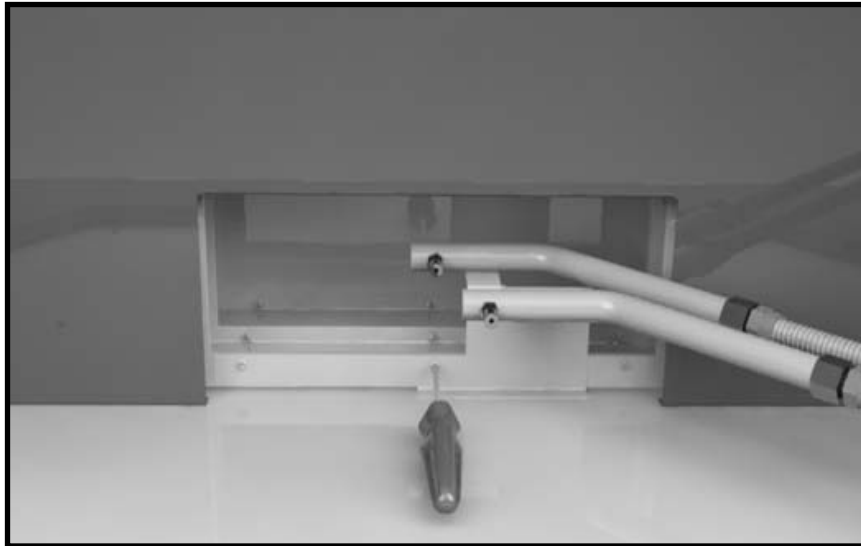

Figure 2: TC54 Black Diamond burner kit contents.

1. Remove one screw from the center rear of the firebox and use it to attach the manifold assembly. (Figure 2)
2. Remove the 2 screws from the firebox bottom. (Figure 4)
3. Attach the manifold supply tubes from the "T" to the fittings on the two manifolds(Figure 3)

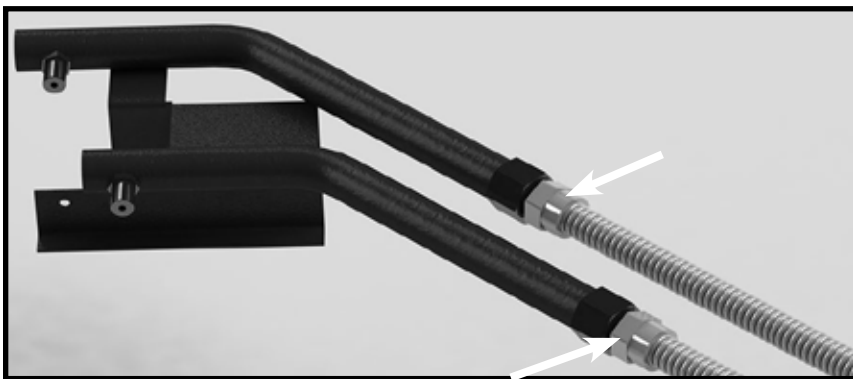

Figure 3: Attach main gas supply tubes from the "T" to manifolds.

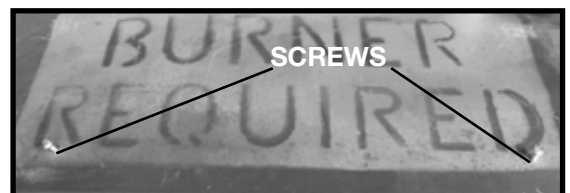

Figure 4: Screws in floor.

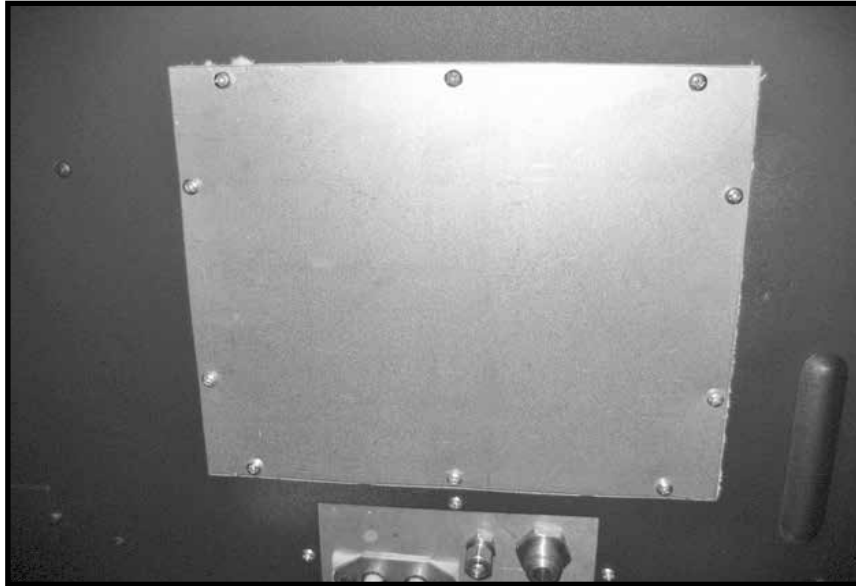

Figure 5: Remove access panel.

4. Remove access cover to the valve control center from the right side of the fire box (Figure 5).
5. Attach the center supply tube from the “T” and the pilot gas supply tube to the bulk head fitting and tighten (Figure 6).

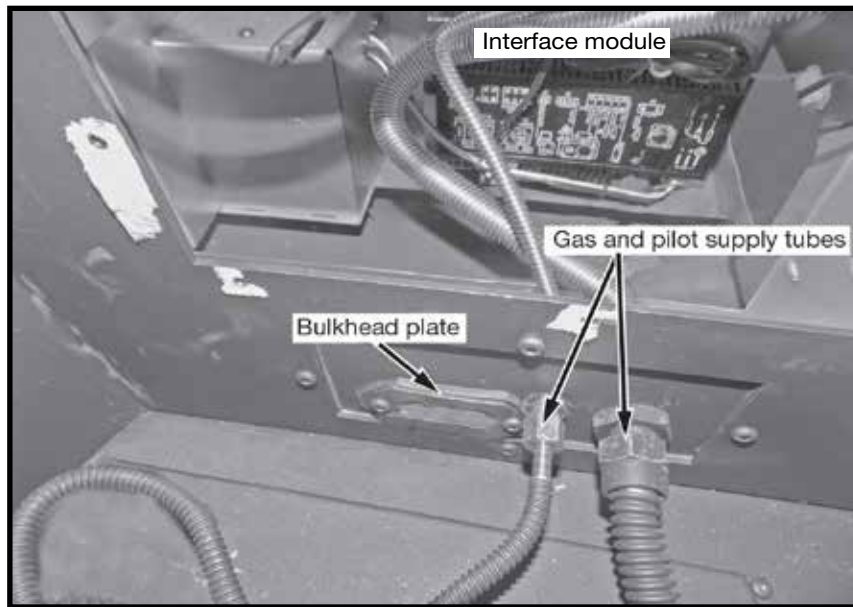

Figure 6: Attach gas supply tubes to bulkhead

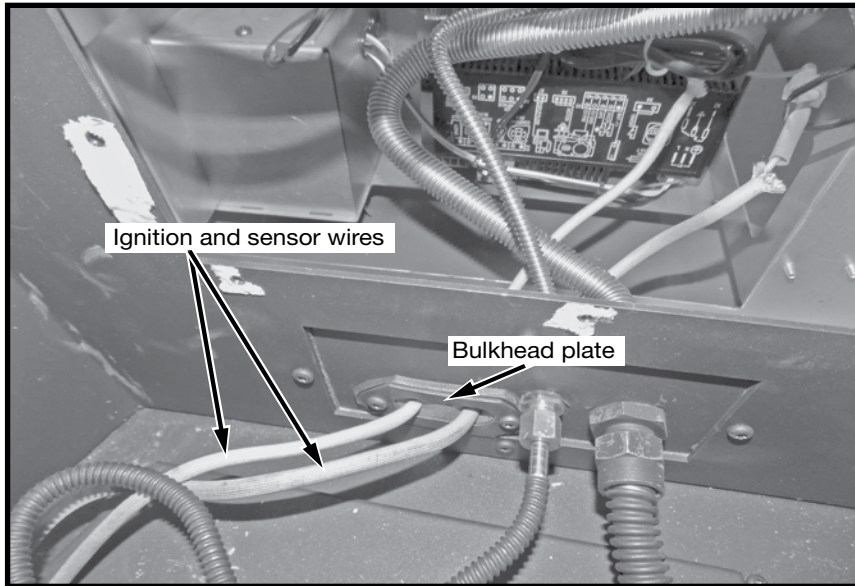

Figure 7: Remove access panel.

6. Feed the ignition and sensor wires through the bulkhead plate to the interface module. (Figure 7).
7. Attach the ignition and sensor wires to the interface module as shown in (Figure 8).

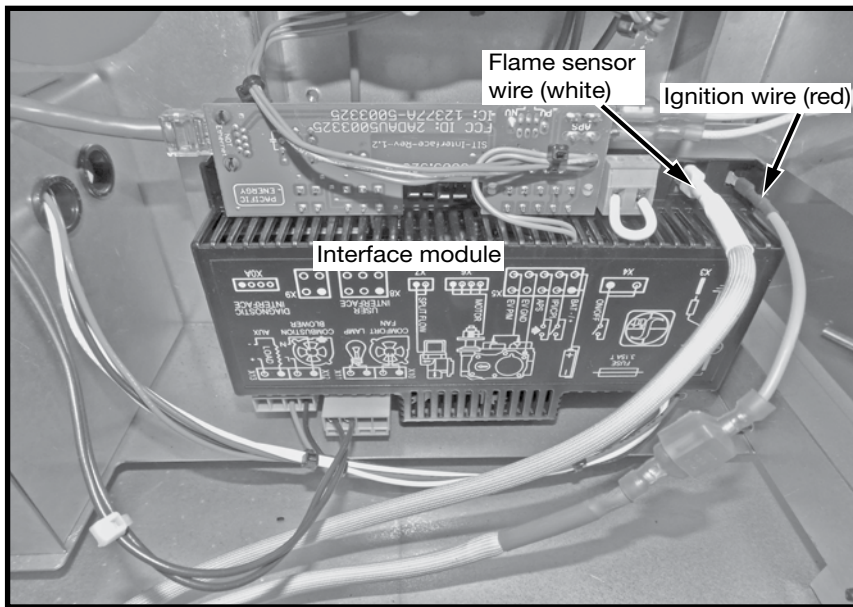

Figure 8: Interface module.

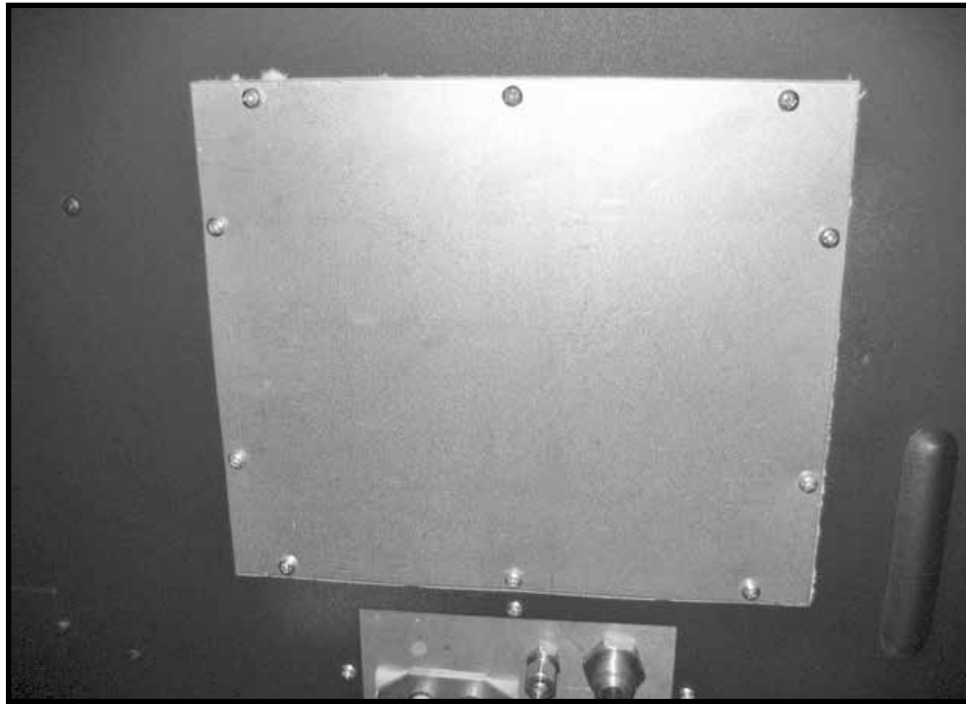

Figure 9: Replace access panel.

8. Re-install the access panel in the right side of the firebox (Figure 9).
9. Place burner shield into unit, flexing right shield leg slightly to clear manifold. Make sure the pilot protrudes through the center hole. (Figure 10).

NOTE: The shield sits at an approximately 15 degree angle to the base of the firebox.

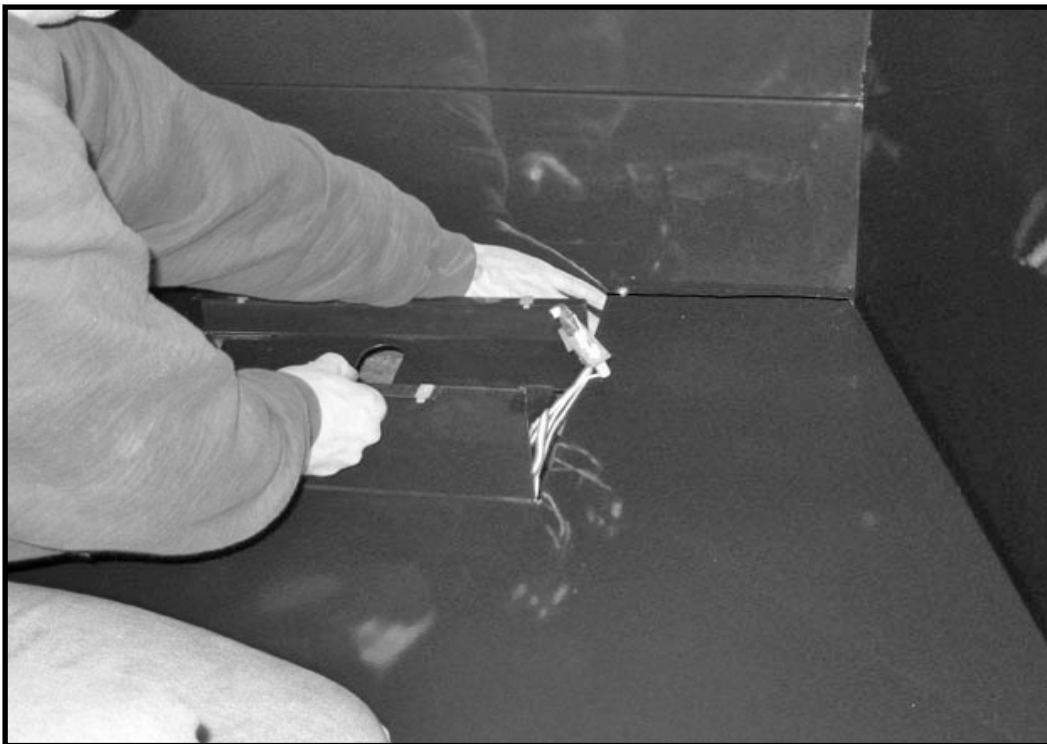

Figure 10: Install shield.



Figure 11: Attach pilot.

10. Cover the glossy surface of the burner shield to prevent surface damage while connecting pilot to the underside of the burner tray. (Figure 11)

NOTE: Start screws with fingers first to prevent cross-threading.

11. Place front media spacer into the front of the tray. (Figure 12)

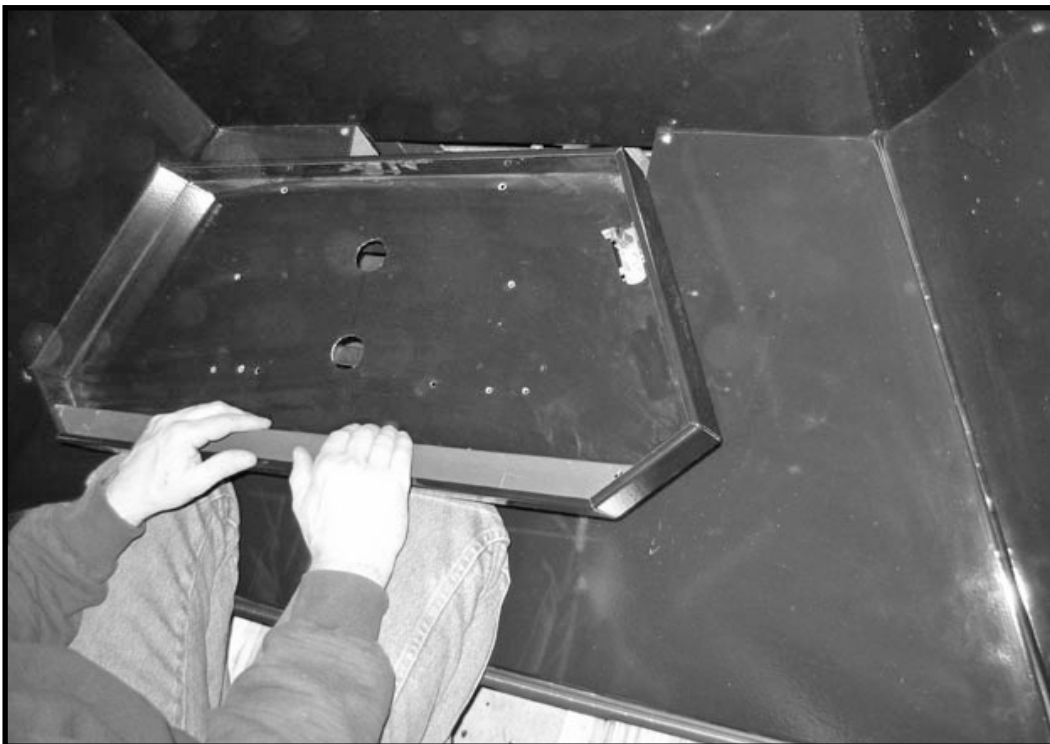

Figure 12: Install front media spacer.



Figure 13: Installing front burner.

11. Install front burner tube by tilting it into the front tray hole until almost fully seated. (Figure 13)

Set the air shutter to fully open for Propane or fully closed for Natural gas.

12. Guide tray and burner tube back until the burner tube engages the forward orifice. This can be seen through the rear burner hole. (Figure 14)

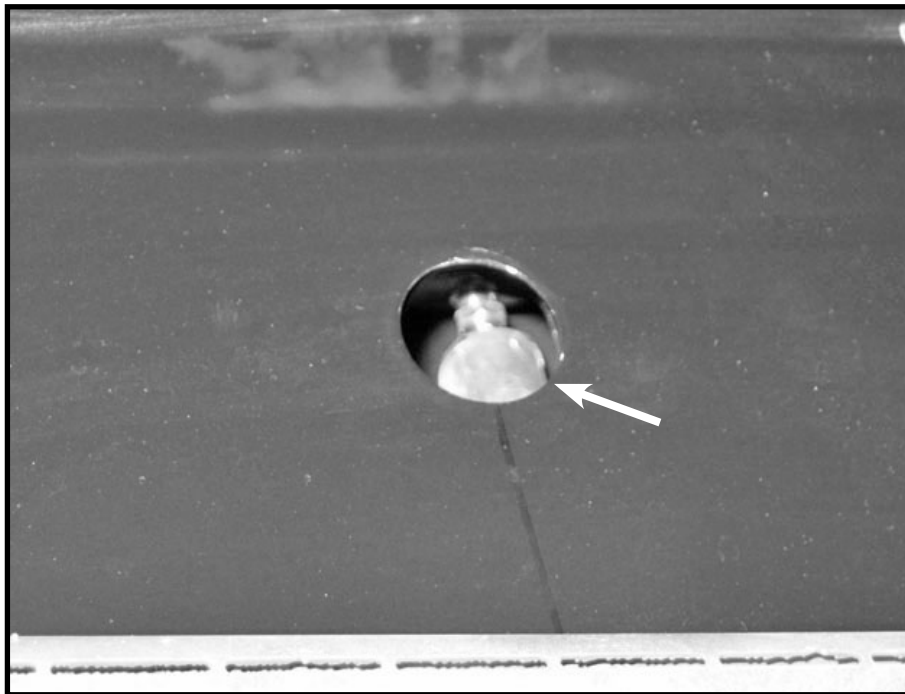

Figure 14: Burner tube placement



Figure 15: Attach tray to shield.

13. Attach burner tray to shield with four screws. (Figure 15)

14. The rear media spacer is now installed. (Figure 16)

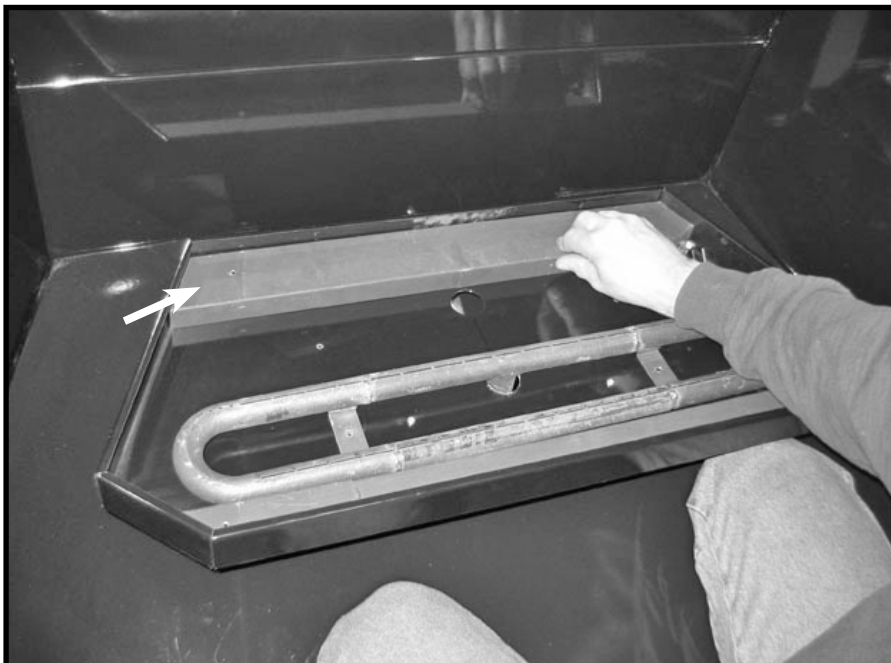

Figure 16: Rear media spacer.



Figure 17: Install Rear burner.

14. Install rear burner by tilting the inlet through the rear hole in the tray. Engage the inlet with the rear orifice. This can be seen from the back of the tray.(Figure 17)

Set the air shutter to fully open for Propane or fully closed for Natural gas.

15. Install center media spacers and screw down through burner and tray with 1 1/2" screws. (Figure 18). Three holes must line up to set each screw.



Figure 18: Center media spacers.

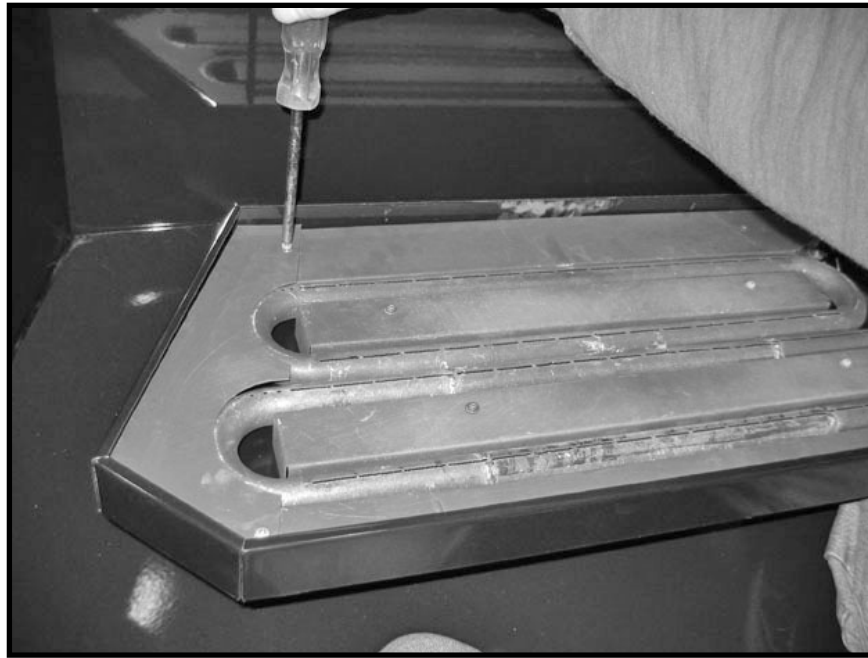

Figure 19: Left media spacer.

16. Install the left media spacer and secure to front and rear media spacers with two screws. (Figure 19)

17. Install right media spacer and secure to front and rear media spacers with two screws. (Figure 20)

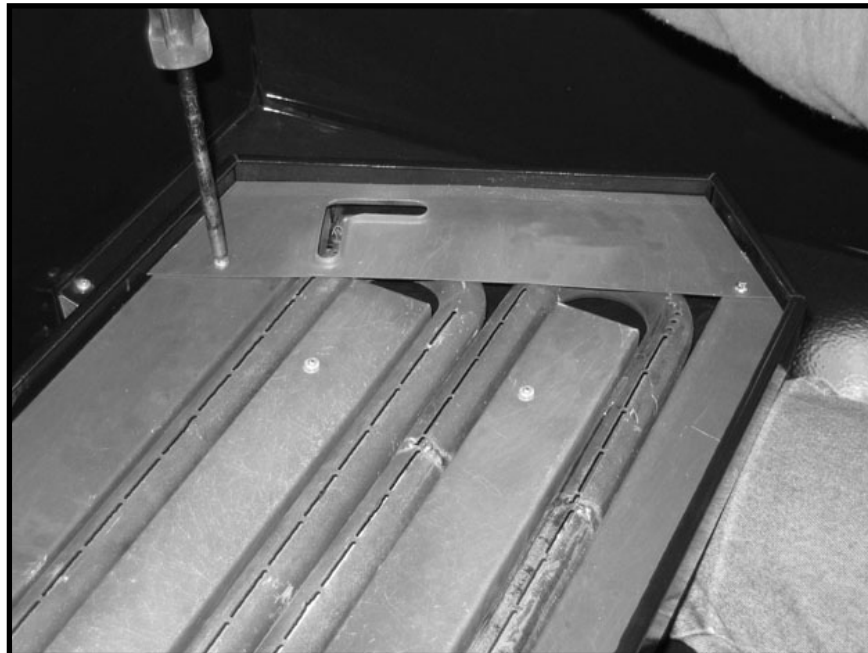

Figure 20: Right media spacer.



Figure 21: Glass media.

18. Apply just enough glass media to cover the burner assembly. (Figure 21 & 22)

Use caution not to get any glass media into the pilot slot.

NOTE: Too much tumbled glass over the burner will cause sooting with the use of propane gas.



Figure 22: Glass media appearance.

Propane Conversion

WARNING

This conversion kit shall be installed by a qualified service agency in accordance with the manufacturer's instructions and all applicable codes and requirements of the authority having jurisdiction.

If the information in these instructions is not followed exactly, a fire, explosion or production of carbon monoxide may result causing property damage, personal injury or loss of life.

The qualified service agency is responsible for the proper installation of this kit. The installation is not proper and complete until the operation of the converted appliance is checked as specified in the manufacturer's instructions supplied with the kit.

CAUTION

The gas supply and electrical power must be shut off before proceeding with the conversion.

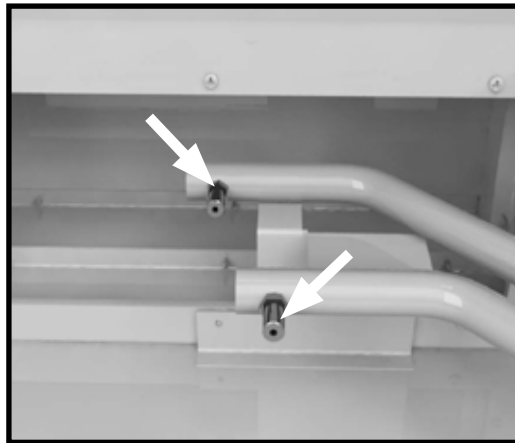

Figure 23: Remove NG orifices.

Note:

Factory supplied components must be used to ensure correct input. After conversion confirm proper manifold pressure.

1. Ensure the burner, pilot and gas supply are turned off, and the appliance has cooled.
2. Using a 1/2" wrench, undo both natural gas burner orifices (marked "ND").(Figure 23)
3. Apply a small amount of pipe joint compound to the threads of the propane burner orifice (marked "LD") to ensure a good seal, before screwing it into the manifold.
4. Open primary air shutters fully.
5. With a 7/16" wrench loosen the pilot head on the pilot assembly (Figure 24)



Figure 24: Loosen pilot head.



Figure 25: Band in NG position.

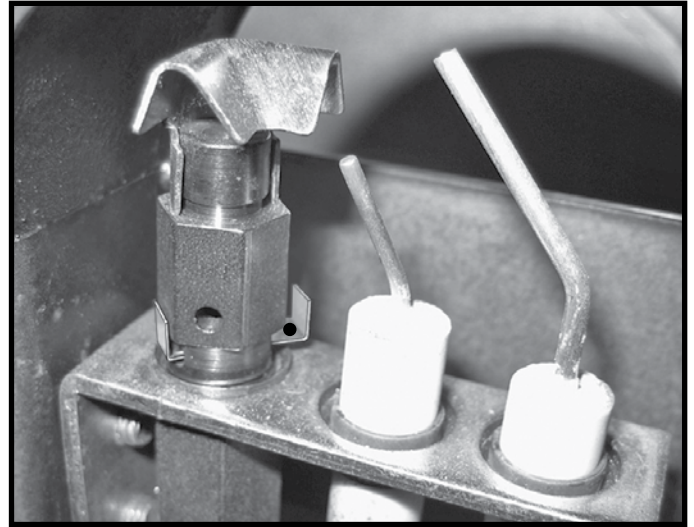

Figure 26: Band in LP position.

6. Slide the pilot adjustment band over and ensure that the hole in the orifice band is showing. (Figure 25 indicates NG position, Figure 26 indicates LP position)
7. Fill in the conversion label. Peel off the protective backing and apply the conversion label directly over the gas specifications on the rating label.

This appliance was converted to propane gas		
Kit Number	PACIFIC ENERGY	
	5052.52001-B	
dd / mm / yy	correction faite.	
	conversion a été	
	responsabilité que cette	
Company	ci-dessus accepte la	
	l'entreprise désignée	
Address	Adresse	
The above accepts the responsibility that this conversion has been properly performed.	Firme	
	a m j	
5052.52001-B	Numéro d'assemblage	
PACIFIC ENERGY		
Cet appareil a été converti en gaz propane		

For complete valve installation instructions, refer to the instruction book included in the SIT conversion kit.

Gas Pressure Check

Note: To test the gas pressure, turn off the gas supply before removing the plug from the supply pressure test port or manifold pressure test port.

Verify gas pressures with the fireplace lit and on the highest setting.



Figure 27: Remove plugs.

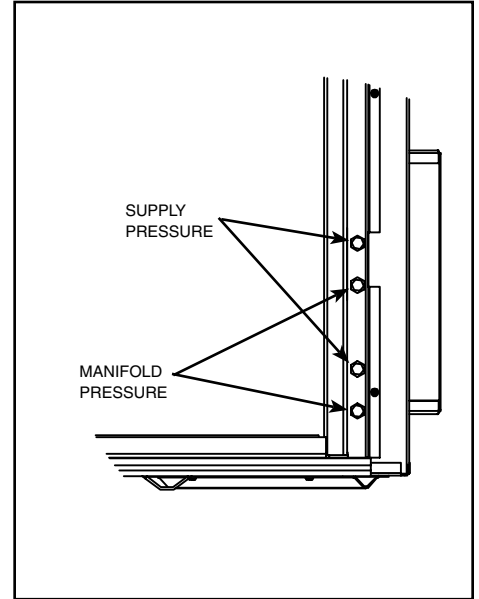

1. Remove the plug from the pressure test port. The plug is located between the right side lintel and firebox side. (Figure 27)
2. Thread the extension test fitting into the open test port. (Figure 28)
3. Attach a pressure gauge onto the fitting.
4. When testing is complete remove the extension test fitting and replace the plug. Thread sealant will be required to ensure a gas tight connection.



Figure 28: Pressure adjustment.

Correct gas pressure requirement:

Supply Pressure	Natural Gas	Propane
Min. Pressure <small>(For purpose of input adjustment)</small>	5.0" WC	12.5" WC
Max. Pressure	13.9" WC	13.9" WC
Manifold Pressure		
Maximum	3.5" WC	10" WC
Minimum	1.6" WC	6.4" WC

Burner Flame Adjustment

The air shutter on the burner tube controls the primary combustion air to the gas burner. The shutter should be set to fully closed for natural gas or fully open for propane. See Figure 29 for proper flame pattern.



Figure 29: Flame appearance.

The flame should be just orange and “lazy”.

It should NEVER be set to create sooting on internal parts and window glass.

Parts Diagram

(WHEN ORDERING, INCLUDE PART NUMBER WITH DESCRIPTION)

ITEM.....DESCRIPTION	PART NO.
#1 TC54 BLACK DIAMOND BURNER KIT	22150048
#2a BURNER TUBE	TC54. 50118305
#2b BURNER TUBE	TC42. 5011832.A
#3 PILOT ASSEMBLY, CONVERTIBLE	80000525
#4 ORIFICE, NG marked "ND" (2 Required).....	80002042
* #5 MANIFOLD ASSEMBLY	TC54.9654
* #6 GLASS MEDIA	TCRP.501201
* #7 PROPANE CONVERSION KIT	22180009

* NOT SHOWN

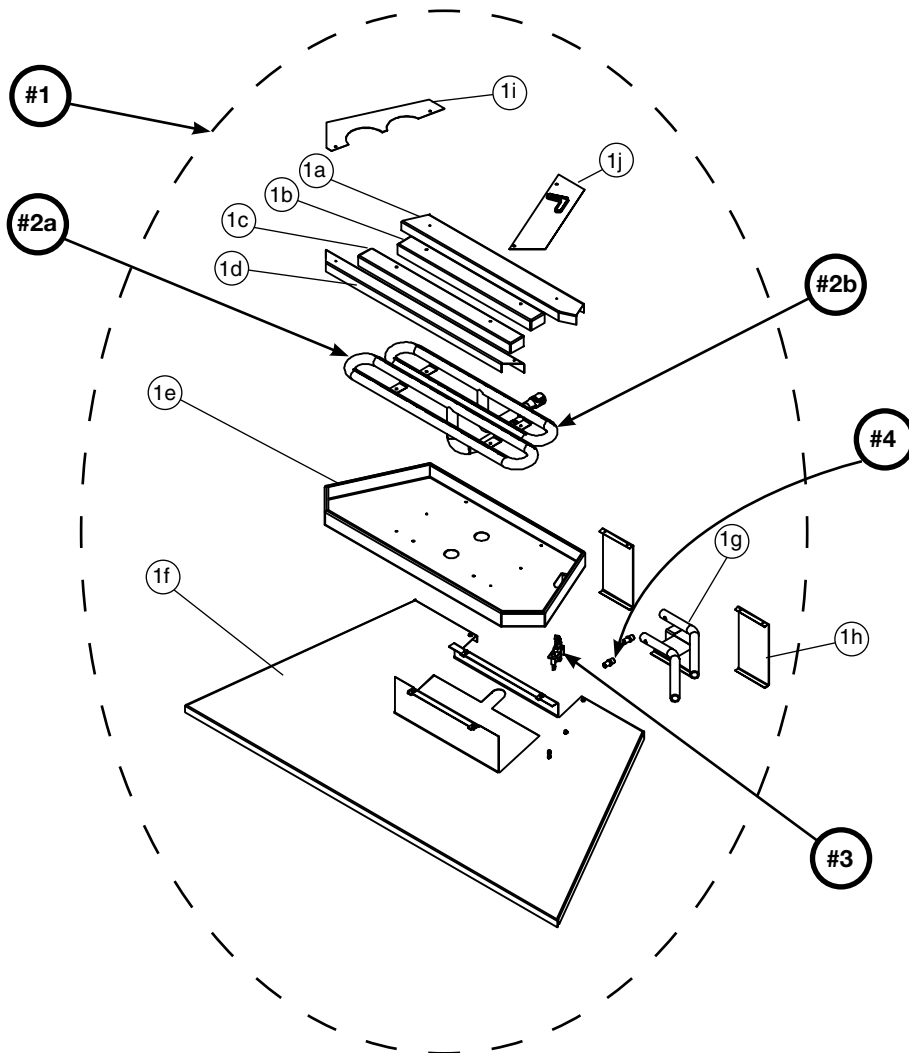



© 2023 Copyright Pacific Energy Fireplace Products LTD

Reproduction, adaptation, or translation
without prior written permission is prohibited,
except as allowed under the copyright laws.



For technical support, please contact your retailer.

**Web site: www.townandcountryfireplaces.net
2975 Allenby Rd., Duncan, BC V9L 6V8**