

**INSTALLER: Leave this manual with the appliance.  
CONSUMER: Retain this manual for future reference.**

These instructions are supplementary to the Installation and Operating Instructions supplied with the fireplace and should be kept together. Refer to the Installation and Operating Instructions for proper gas supply, safety requirements and operating instructions



**TOWN & COUNTRY**  
LUXURY FIREPLACES

# **TC36 BLACK DIAMOND BURNER KIT INSTRUCTIONS**



**PART #TC36.NG03C**

**For use with:  
Model: TC36  
Series: C**



## Package Contents



- BURNER TUBE
- MEDIA SPACER, Rear
- BURNER TRAY ASSY
- MEDIA SPACER, Front
- 5 lbs. TUMBLED GLASS
- MEDIA SPACER, Center
- BURNER SHIELD
- PANEL, LOWER REAR
- MANIFOLD ASSEMBLY (including supply tube)
- PILOT SHIELD (including pilot and supply tube)
- HARDWARE PACKAGE

NOTE: MUST BE USED WITH PORCELAIN PANEL SET PART# TCPN.757031.C

## Burner Installation



**A porcelain panel set must be used in conjunction with the installation of the burner assembly.**

- 1) Remove 2 screws from the air channel and attach the lower rear panel to the firebox with these screws. (Fig. # 1)

**NOTE: The burner shield may need to be loosened and re-tightened after positioning if the panel does not slip in behind it.**

- 2) Attach the manifold bracket to the floor shield in the bottom of the firebox with one screw. (Fig. # 2)

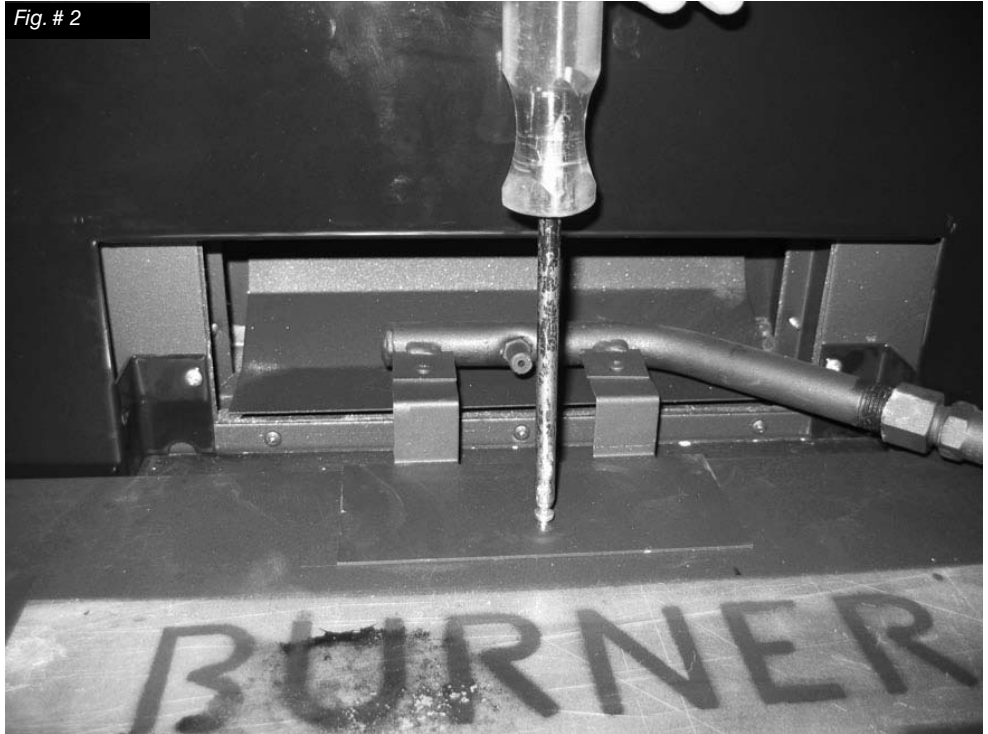

- 3) Attach the manifold and pilot supply tubes to the bulk head fitting and tighten. (Fig. # 3) Ensure that all connections are gas tight.



4. Secure the electrical bulkhead plate and gasket to the firebox. (2 screws) Attach the ignition and sensor wires to the module. Red end to the connector marked by the red dot, white end to the connector marked by the white dot(Fig. #4 & 5)

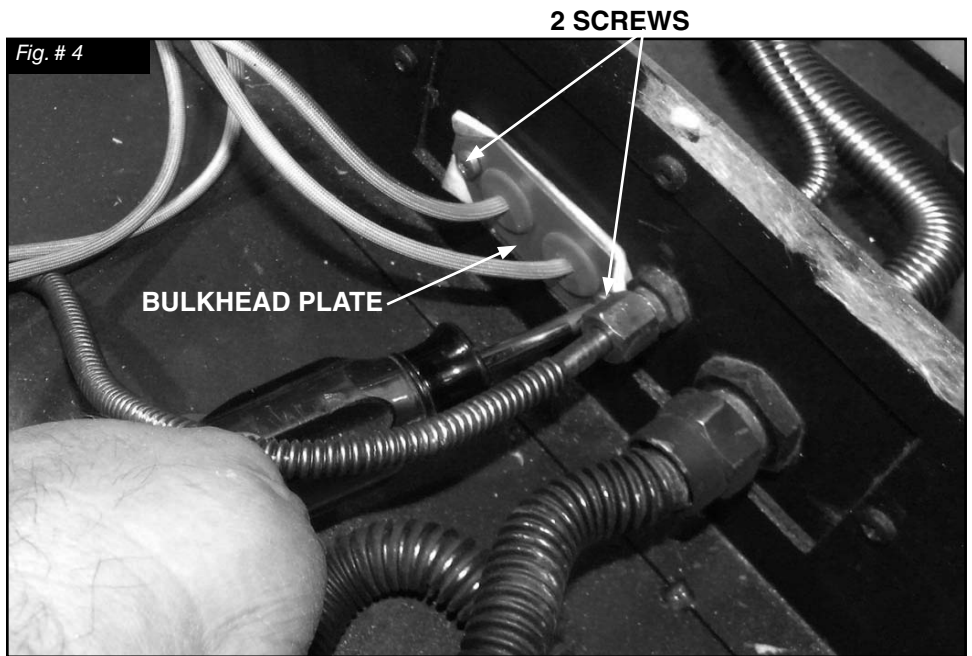

**NOTE:** If converting to propane refer to the propane conversion section before continuing. Pg. 12

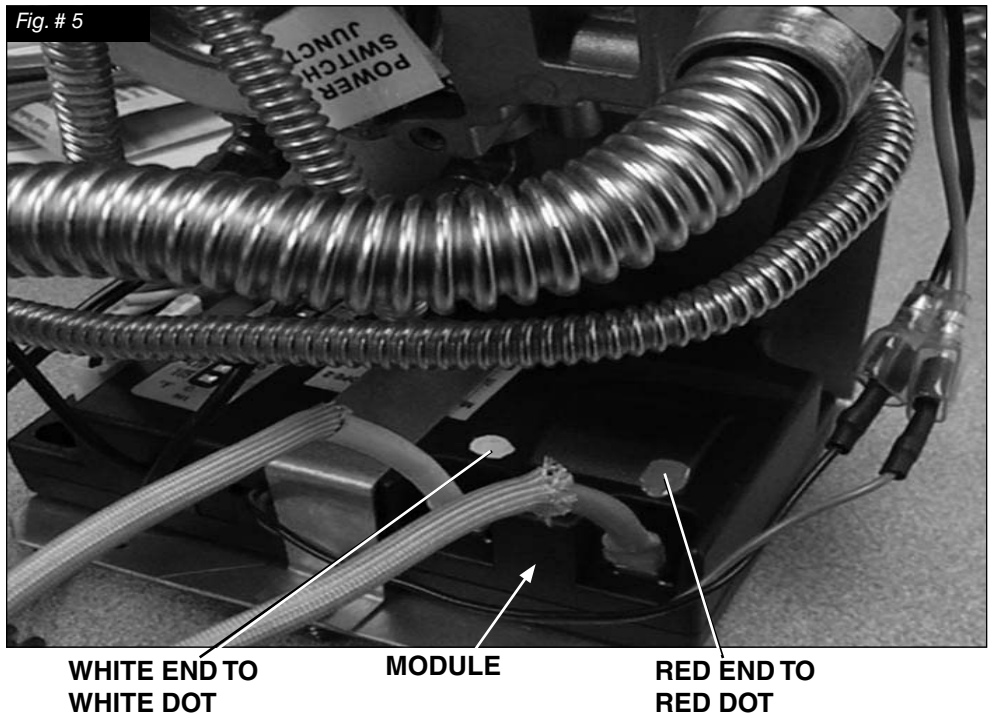

- 5) Remove panel retainer from the upper heat shield. Install right side panel by placing the bottom into the firebox and tipping the top into position. (Fig. # 6)

Fig. # 6



- 6) Position upper rear panel on top of lower rear panel and slip in behind the right panel. (Fig. # 7)

Fig. # 7



- 7) While supporting the upper rear panel install the left side panel in the same manner as the right side panel. Secure both side panels with the previously removed panel retainer. (Fig. # 8)



- 8) Install burner shield by tipping the shield into the firebox, feed the pilot assembly through the opening in the shield. (Fig. # 9)



- 9) With a short, stubby screwdriver, attach pilot shield to burner tray with two screws.  
(Fig. # 10)



- 10) Attach the burner tray to the burner shield using two screws at the back of the tray. (Fig. # 11) Ensure that front mounting holes are aligned inder tray before tightening.

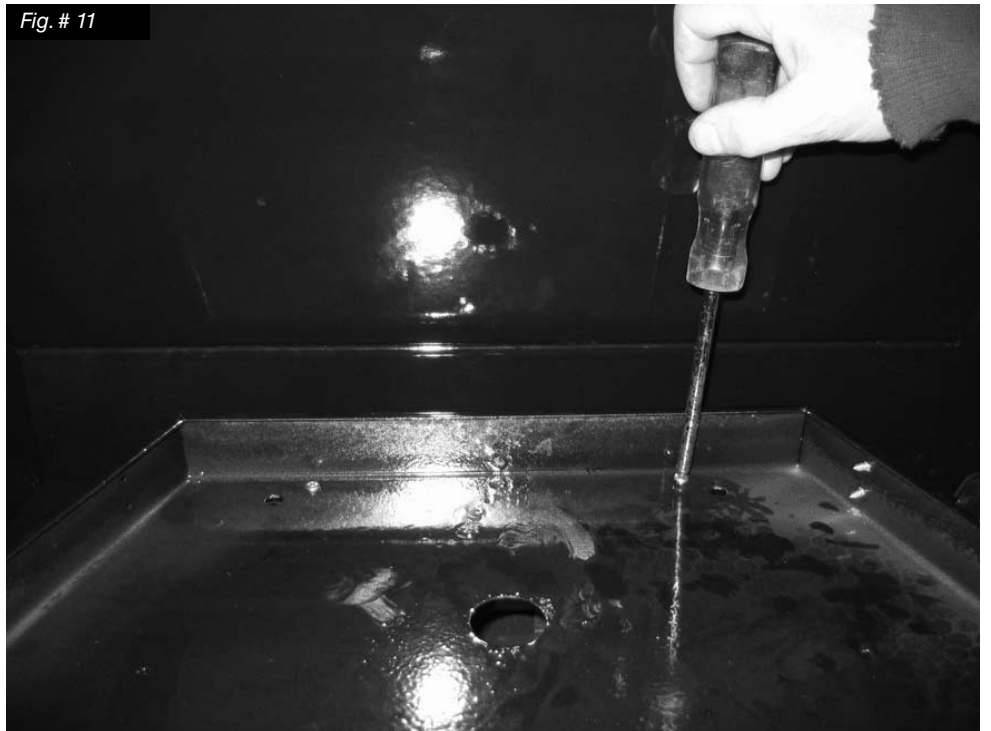

- 11) Install front and rear media spacers.  
(Fig. # 12 & 13)

Fig. # 12

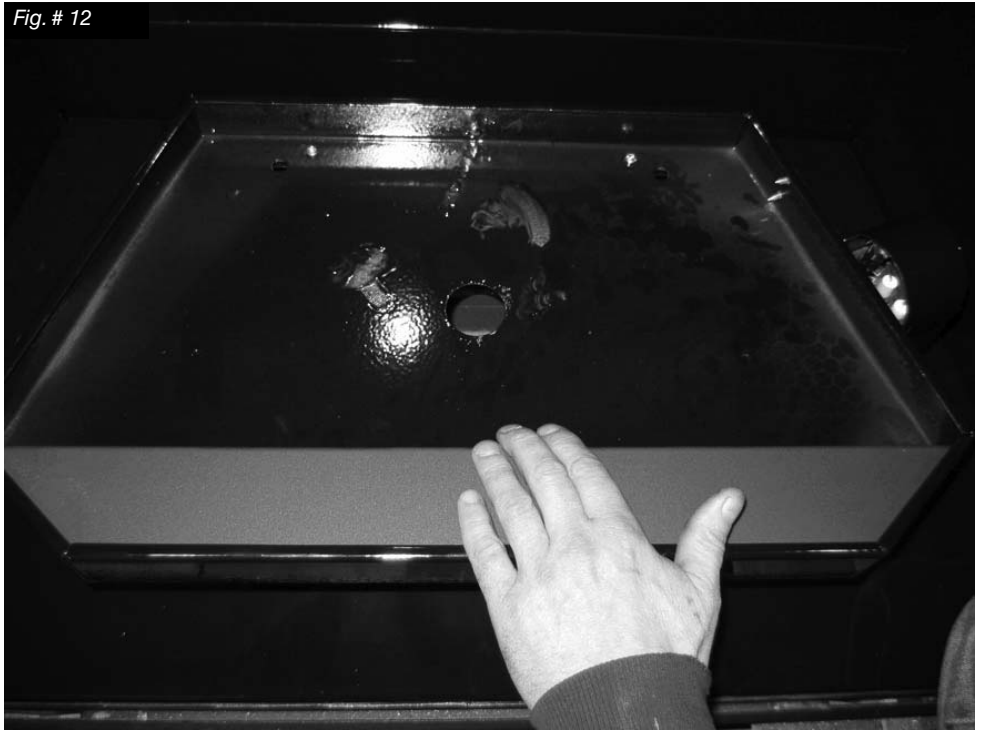

Fig. # 13





- 12) Install burner by tilting burner tube through the tray. Ensure that the orifice has entered the tube.  
(Fig. # 14 & 15)

**Set the air shutter to fully open for Propane or fully closed for Natural gas.**

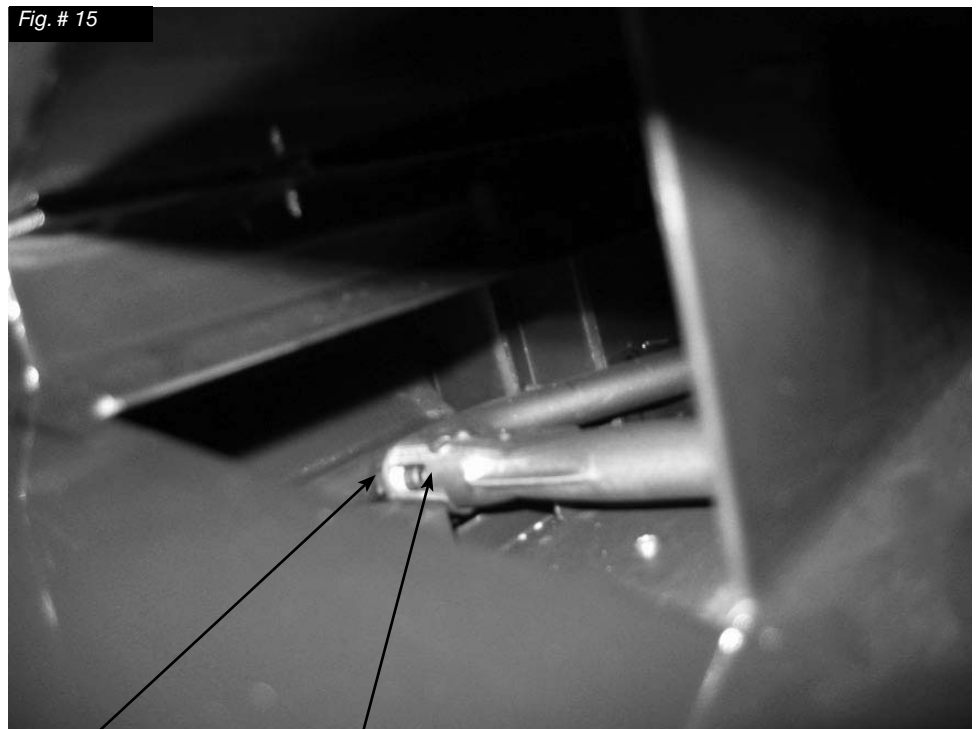
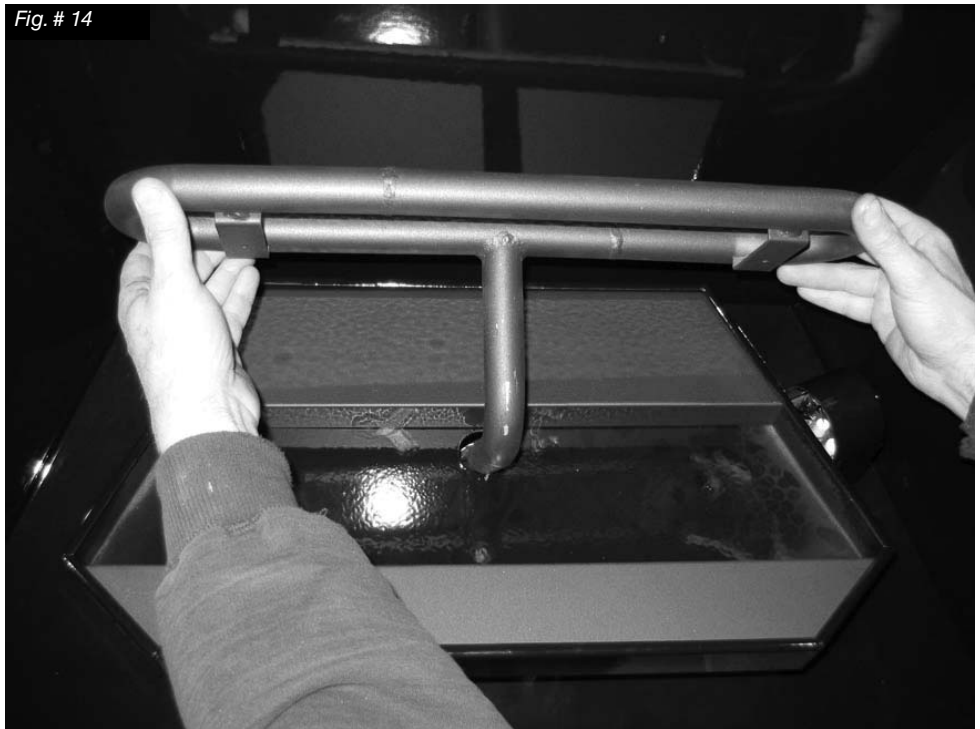

ORIFICE

INLET TUBE

- 13) Install the center media spacer. Secure the spacer and burner with two long screws.(Fig. # 16) Four holes must line up to set each screw. Some pressure may need to be applied to the front tray support on the shield to align the holes. (Fig. # 17)

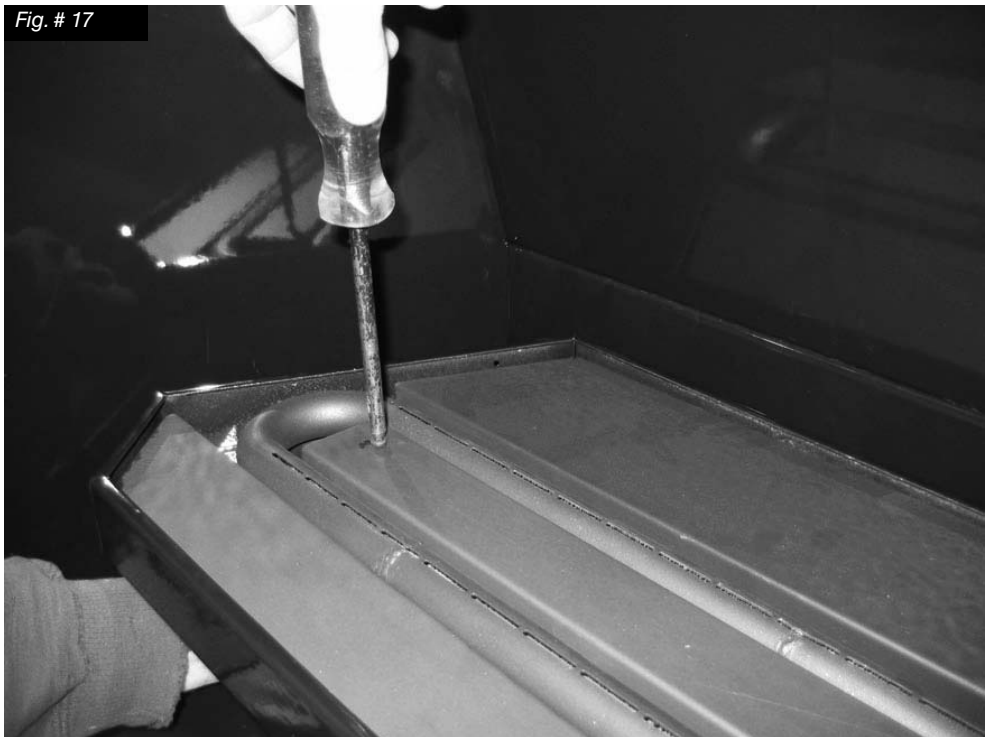

- 14) Apply just enough glass media to cover the burner assembly. (Fig # 18)

**NOTE: Too much glass media over the burner will cause sooting with the use of propane gas**



# Propane Conversion

## WARNING

This conversion kit shall be installed by a qualified service agency in accordance with the manufacturer's instructions and all applicable codes and requirements of the authority having jurisdiction.

If the information in these instructions is not followed exactly, a fire, explosion or production of carbon monoxide may result causing property damage, personal injury or loss of life.

The qualified service agency is responsible for the proper installation of this kit. The installation is not proper and complete until the operation of the converted appliance is checked as specified in the manufacturer's instructions supplied with the kit.

## CAUTION

The gas supply and electrical power shall be shut off before proceeding with the conversion.

If the unit is to be used on propane convert as follows using the components supplied with this fireplace:



For use with model:  
Pour utiliser avec du modèle:

TC36

Date: \_\_\_\_\_

By / Par: \_\_\_\_\_



### LP GAS/ DU GAZ LP

12.5 in/wc / 12.5 po/c.e.  
(3.11 kPa)

13.9 in/wc / 13.9 po/c.e.  
(3.45 kPa)

11.0 in/wc / 11.0 po/c.e.  
(.95 kPa)

# 45 (2.08 mm)

Max.: 47,000 (13.8)

Min.: 35,000 (10.3)

This appliance was converted to PROPANE GAS with this kit on this date by the organization which accepts the responsibility that this conversion has been properly made.

Cet appareil est converti au gaz LP par l'emploi de la trousse de conversion par une organisation qui accepte la responsabilité pour une installation en bon état.

280906 6-TC36 5052.5208

CONVERSION LABEL (5052.5208)

## Note:

Factory supplied components must be used to ensure correct input. After conversion confirm proper manifold pressure.

1. Ensure the burner, pilot and gas supply are turned off, and the appliance has cooled.
2. Using a 1/2" wrench, undo the natural gas burner orifice, (marked #30). (Fig. #19)
3. Apply a small amount of pipe joint compound to the threads of the propane burner orifice (marked #45) to ensure a good seal, before screwing it into the fitting.
4. Open primary air shutter fully.
5. With a 7/16" wrench loosen the pilot head on the pilot assembly (Fig. #20)

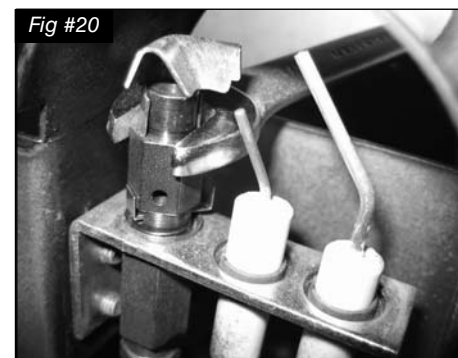

- Slide the pilot adjustment band over and ensure that the hole in the orifice band is showing. (Fig. #21 indicates NG position, Fig. #22 indicates LP position)

Fig #21

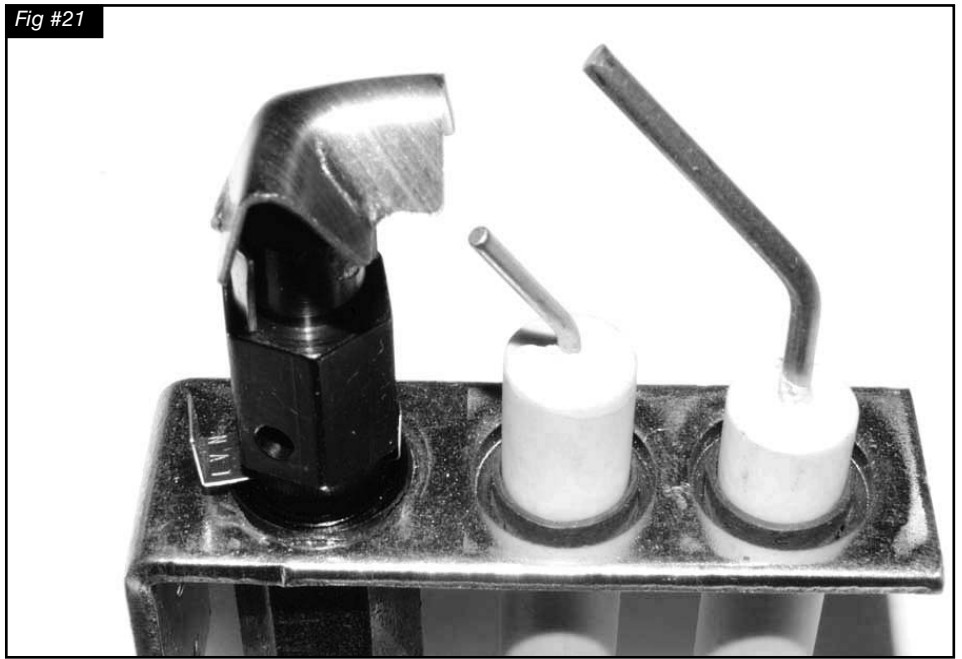

- Remove access panel, 10 screws, and set aside. (Fig. #23)

Fig #22

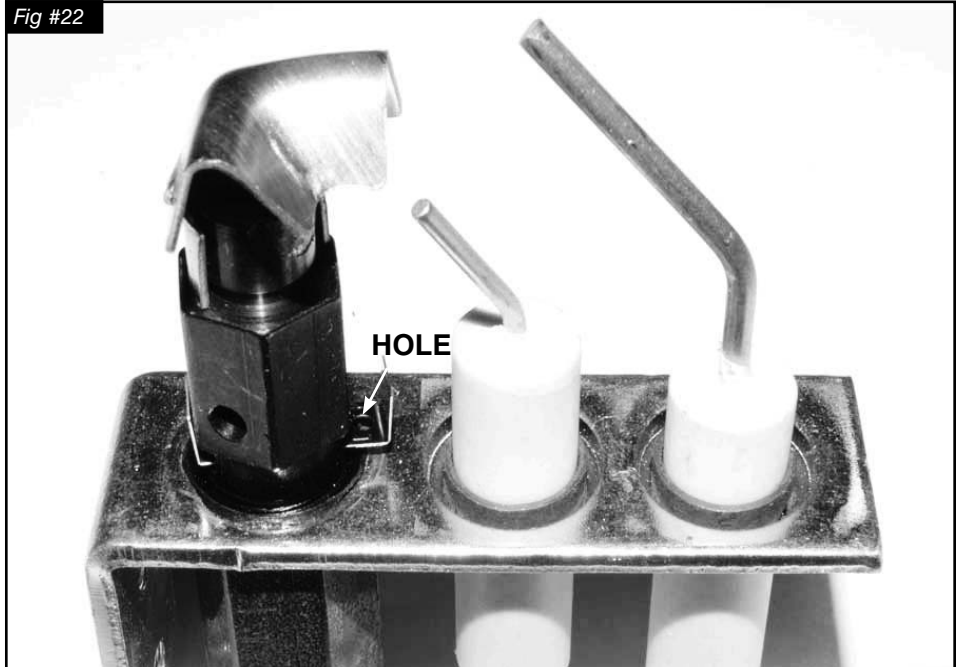

8. Remove the minimum rate screw located in the valve. (Fig. #23)

Fig #23

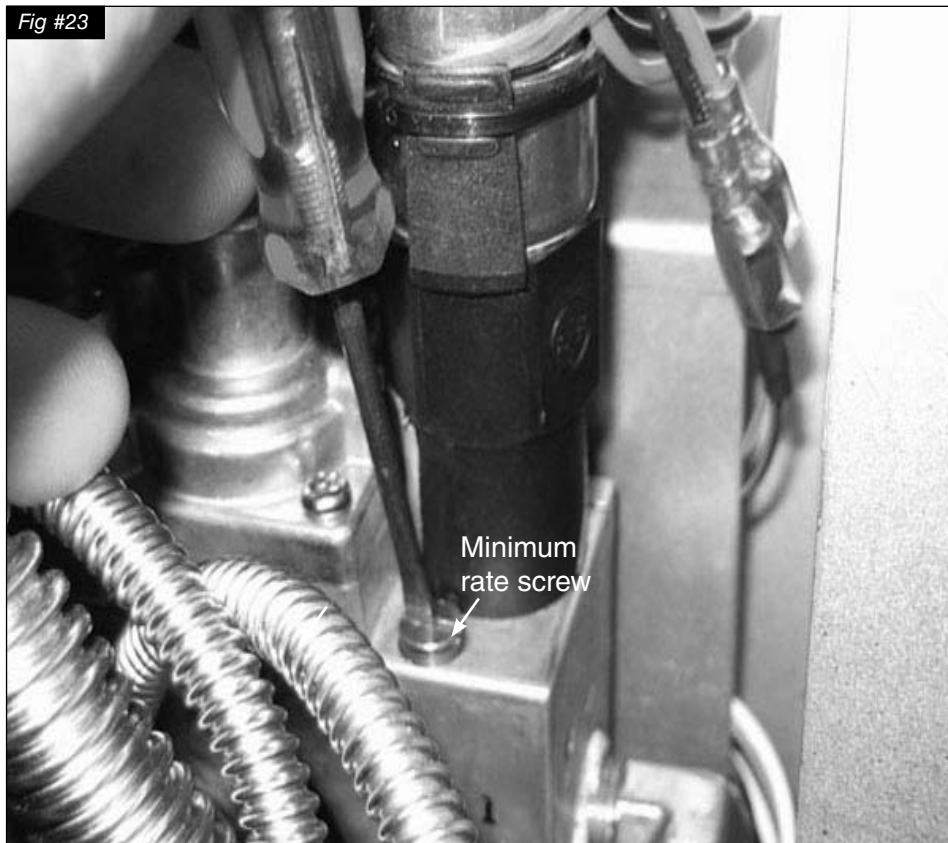

9. Replace the minimum rate screw with the one provided in the propane conversion kit supplied with this burner. Ensure that the screw is fully installed. (Fig. #24)

The minimum rate screw is sealed with an o-ring. Use a thin bladed screwdriver to back the screw out to the limit of the threads.

A groove on the screw body will be visible just above the valve body. Insert a thin tool (knife blade or thin screwdriver blade) into the groove and gently pry the screw up.

It helps to rotate the screw while lifting on it.

Fig #24



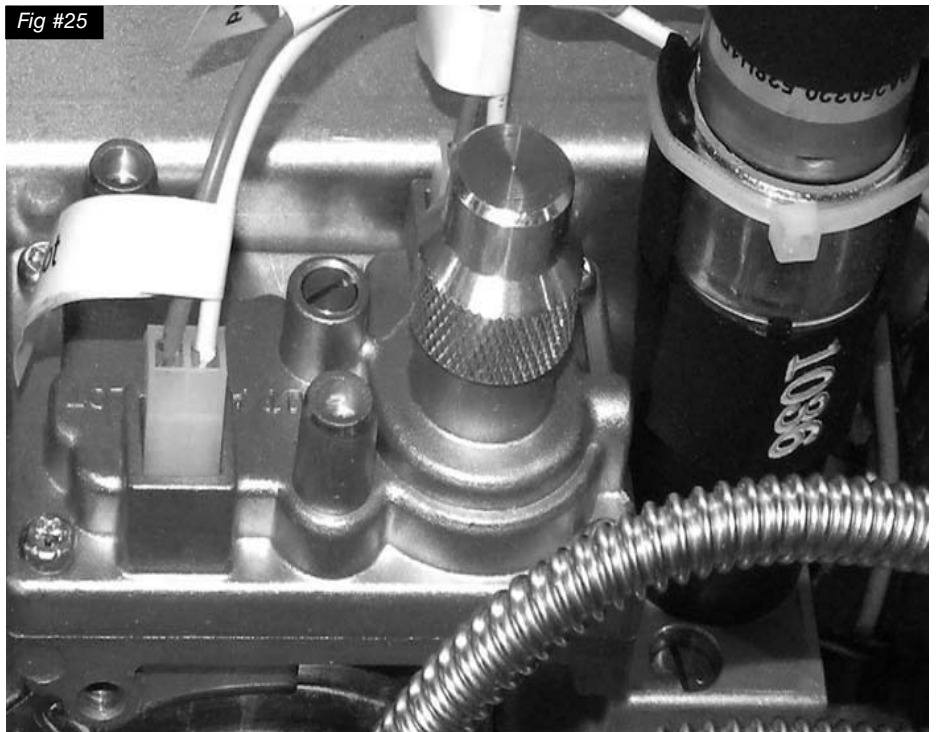

- 10) Pull off the aluminum cap from the top of the pressure regulator. (Fig. #25)

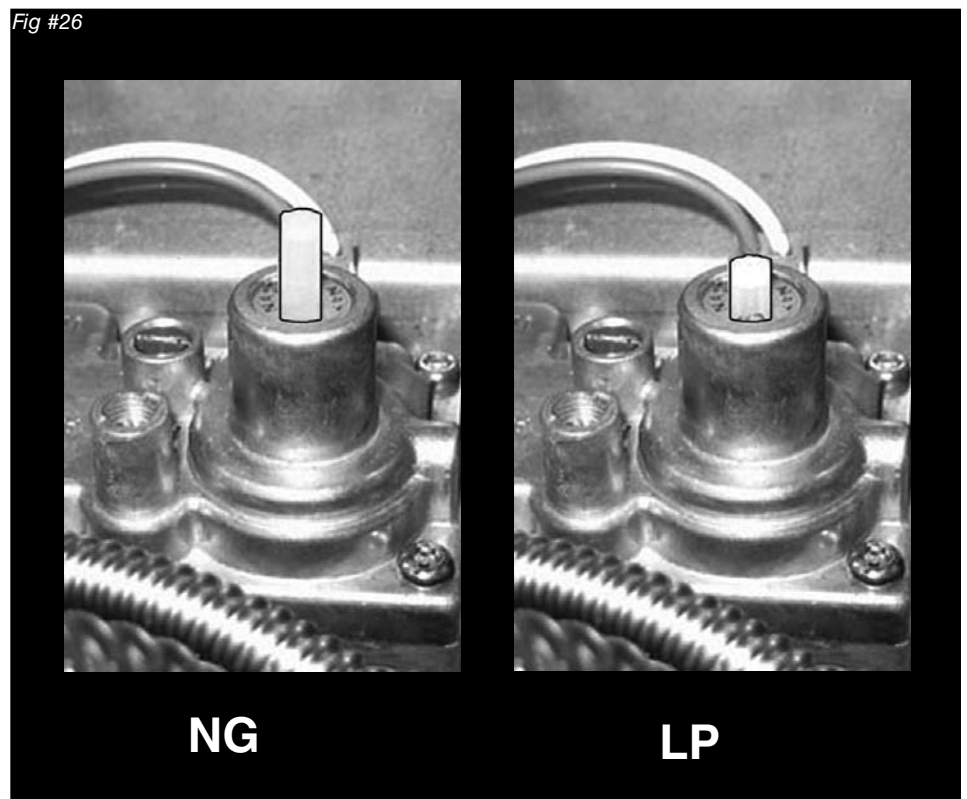

- 11) Press down on the center post and rotate 90°. The center post should stay down. (Fig. #26). Replace the aluminum cap.



12) Fill in the date and the name of the person who performed the conversion in the white area on the conversion label. Peel off the protective backing and apply the conversion label directly over the gas specifications on the rating label.

	For use with model:	<b>TC36</b>
	Pour utilise avec du modèle:	
Date: _____		
By / Par: _____		
<b>LP GAS/ DU GAZ LP</b>		<p>This appliance was converted to PROPANE GAS with this kit on this date by the organization which accepts the responsibility that this conversion has been properly made.</p> <p>Cet appareil etair convertir au gaz LP par l'emploi de la trousse de conversion par une organization qui accepte la responsabilité pour une installation en bon état.</p>
12.5 in/wc /12.5 po/c.e. (3.11 kPa)		
13.9 in/wc / 13.9 po/c.e. (3.45 kPa)		
11.0 in/wc / 11.0 po/c.e. (.95 kPa)		
# 45 (2.08 mm)		
Max.: 47,000 (13.8)		
Min.: 35,000 (10.3)		
		280906    6-TC36    5052.5208

13) Attach the access panel to the side of the firebox with the previously removed screws. (Fig. #27)

**Note: Gasket must be installed with access panel.**

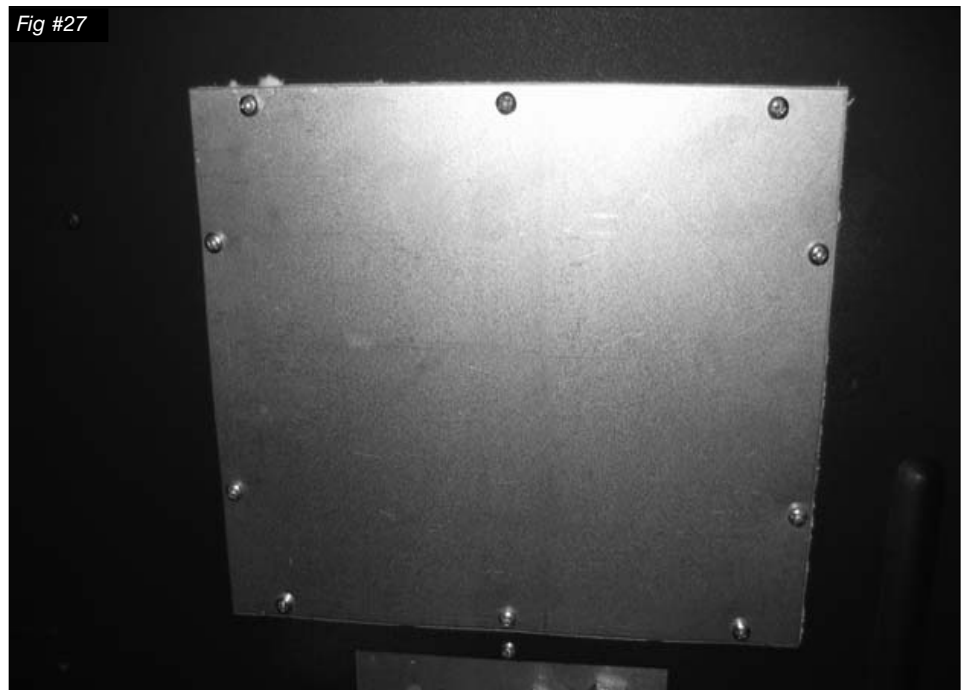



## Gas Pressure Test

**Note:** To test the gas pressure, turn off the gas supply before removing the plug from the supply pressure test port or manifold pressure test port.

Verify gas pressures with the fireplace lit and on the highest setting.

- 1) Remove the plug from the pressure test port. The plug is located between the right side lintel and firebox side. (Fig. # 28)
- 2) Thread the extension test fitting into the open test port. (Fig. # 29)
- 3) Attach a pressure gauge onto the fitting
- 4) When testing is complete remove the extension piece and replace the pipe plug. Thread sealant will be required to ensure a gas tight connection.



### CORRECT GAS PRESSURE REQUIREMENT:

Supply Pressure	Natural Gas	Propane
-----------------	-------------	---------

(For purpose of input adjustment)

Minimum	5.0" wc	12.5" wc
Maximum	13.9" wc	13.9" wc

### Manifold Pressure

Maximum	3.8" wc	11.0" wc
Minimum	2.1" wc	5.5" wc

## Burner Flame Adjustment

The air shutter on the burner tube controls the primary combustion air. It is set to the closed position at the factory for natural gas fuel. For LP see Pg.6. Some adjustment may be necessary to obtain desired flame and to eliminate carbon deposits. Evaluate flame appearance after the fireplace has reached operating temperature. See Fig. #30 for proper flame pattern.

Open primary air if the window glass and firebox have carbon accumulation and/or the flames are long, dark and stringy. The shutter may also be opened to lessen the flame height.

**NOTE:**

**Proper air shutter setting is required.**

**The flame should be just orange and “lazy”. It should NEVER be set to create sooting on internal parts and window glass. Allow the fireplace to run for 30 minutes before evaluating flame appearance.**



# Replacement Parts

NOTE: FIREPLACE & VALVE REPLACEMENT PARTS ARE LOCATED IN THE APPLIANCE INSTRUCTIONS

ITEM.....DESCRIPTION.....PART NO.	ITEM.....DESCRIPTION .....PART NO.
1.....BURNER TUBE.....TC36.5011835WELD	10.....BURNER SHIELD .....9636.001
2.....ORIFICE, NG .....5022.13	11.....BURNER TRAY .....9632.01
.....ORIFICE, LP .....5021.34	12.....PILOT ASSEMBLY, CONVERTIBLE.....TCRP5005025
.....MANIFOLD ASSEMBLY .....TC36.9788	13.....1/4" FLEX TUBE .....5019.225
3.....MANIFOLD BRACKET .....9631	14.....1/2" FLEX TUBE .....5019.223
4.....MANIFOLD.....TC36.9788WLD	HARDWARE PACKAGE .....TC36.HK03
5.....DORMONT FITTING.....5019.221	
6.....MEDIA SPACER, REAR.....9634	
7.....PILOT SHIELD .....9626.002	
8.....MEDIA SPACER, CENTER.....9635.001	
9.....MEDIA SPACER, FRONT .....9634.5	

Not sold separately

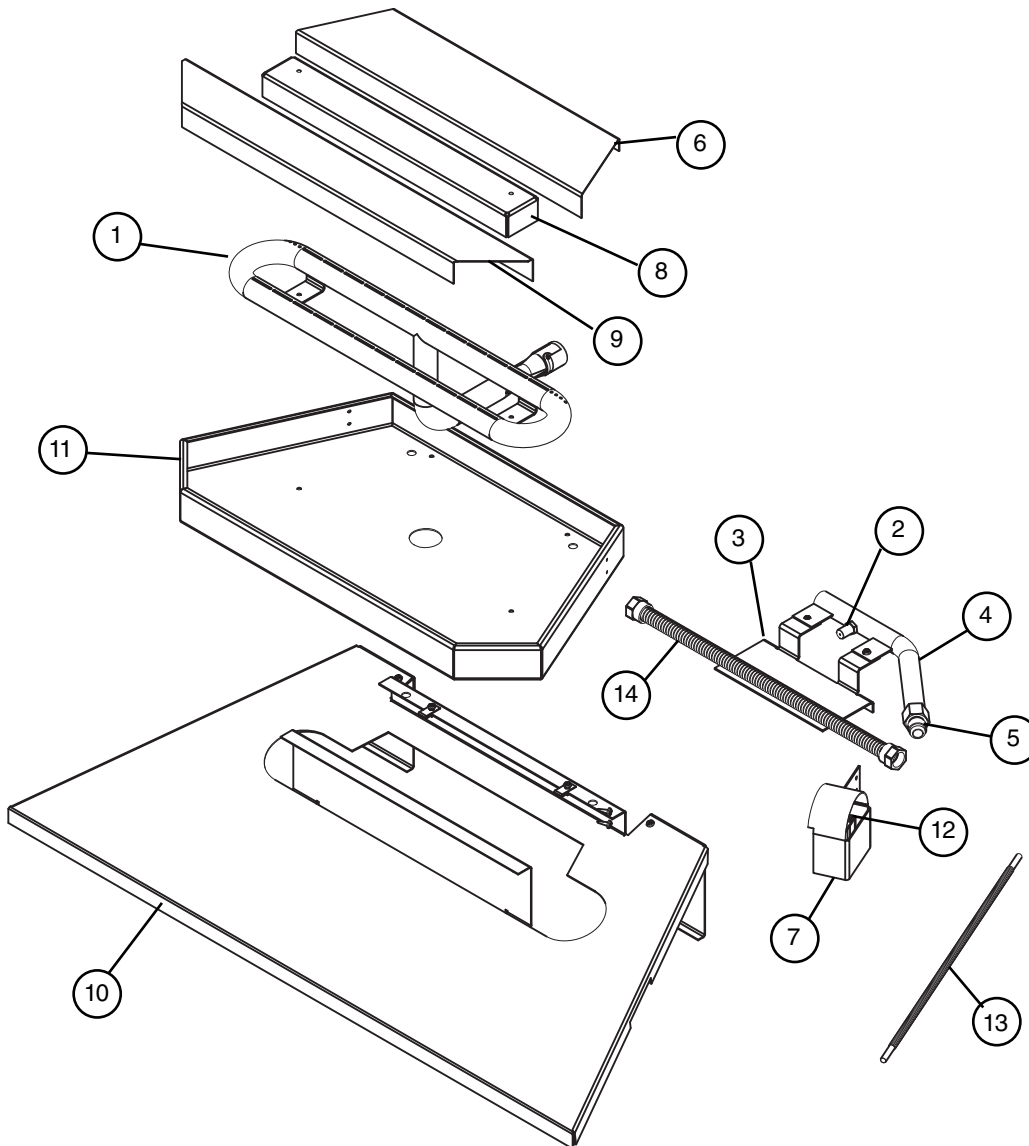



TOWN & COUNTRY  
L U X U R Y F I R E P L A C E S

**TECHNICAL SUPPORT: 1-250-748-1184**  
**[www.townandcountryfireplaces.net](http://www.townandcountryfireplaces.net)**  
**2975 Allenby Rd., Duncan, BC V9L 6V8**