

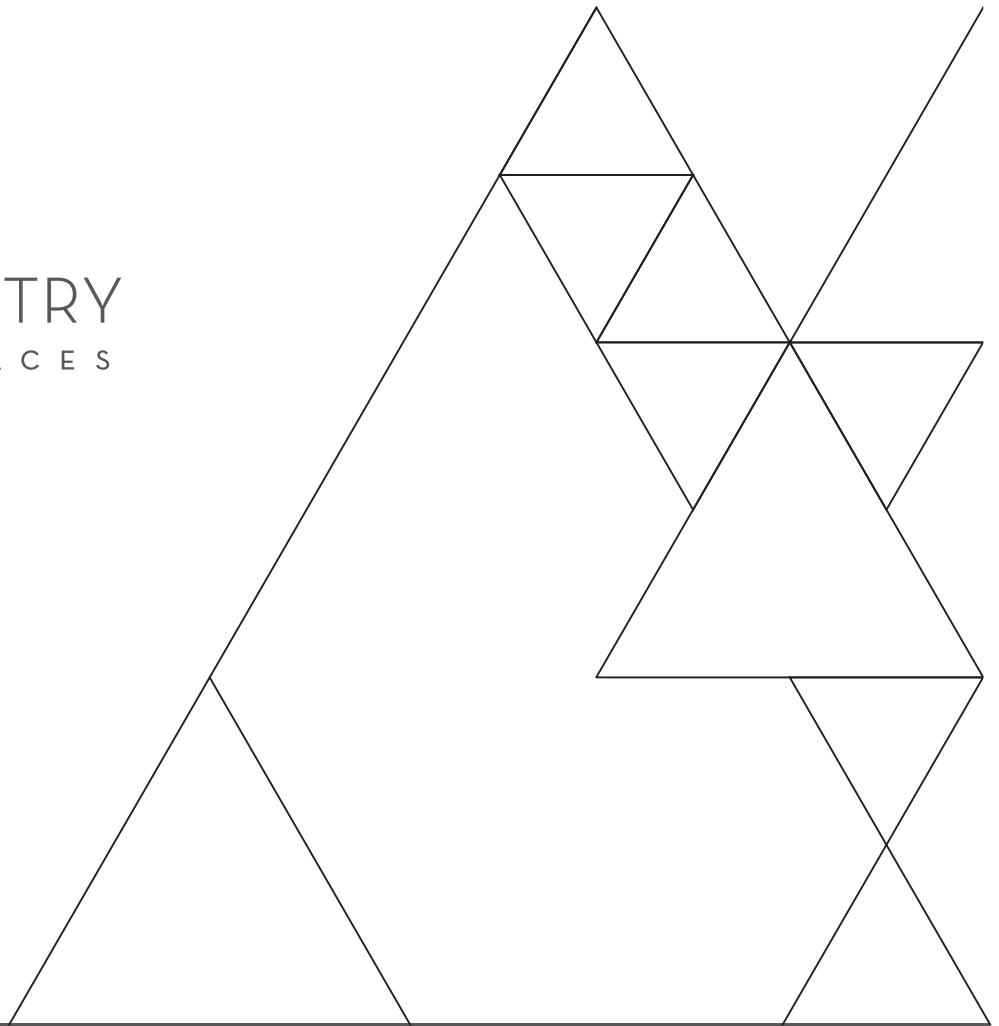

TOWN & COUNTRY
LUXURY FIREPLACES



FOR ARCHITECTS & DESIGNERS

TCWS54ST

SERIES D

Dimensions | Clearances | Venting

IMPORTANT

This booklet is intended as a basic specification guide for architects, designers and builders. Please refer to the Instruction Manual supplied with the fireplace for detailed information regarding installation and operation.

Product installation manuals can also be viewed at:
www.townandcountryfireplaces.com

Fireplace Dimensions

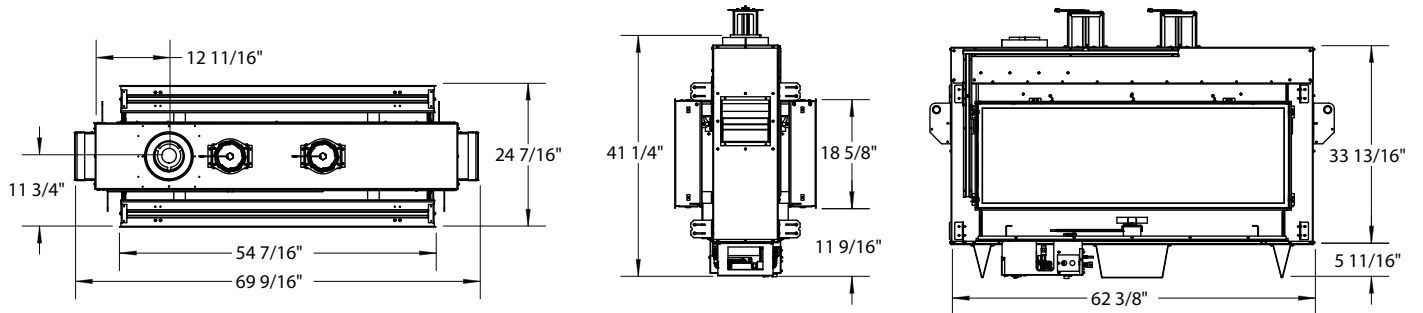

Examples of Common Locations

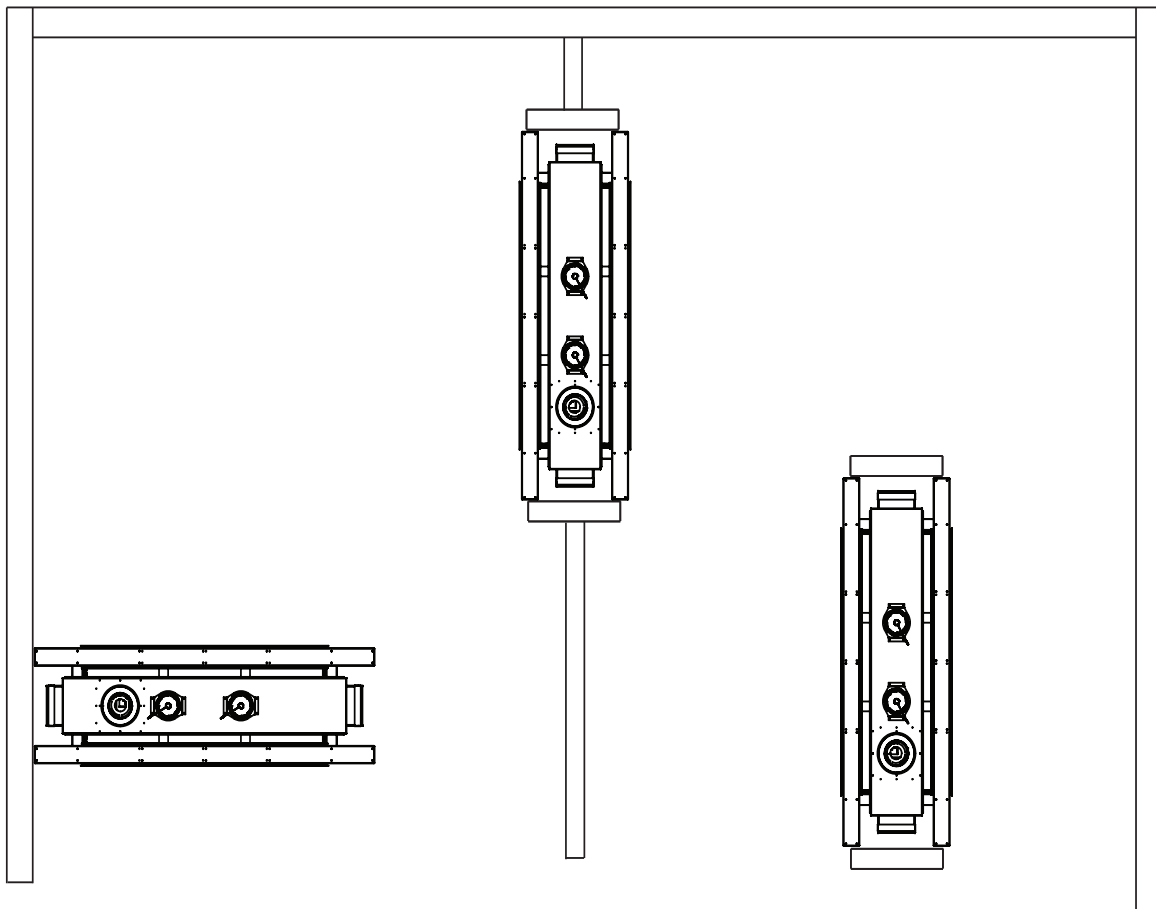

TCWS54STD Cad Drawing
Available at
www.townandcountryfireplaces.com

FOR REFERENCE ONLY. CONSULT MANUAL BEFORE INSTALLATION

COMBUSTIBLE FRAMING AND FINISH WALL ABOVE STANDOFFS

NON-COMBUSTIBLE ZONE.
DO NOT INSTALL ANY COMBUSTIBLE MATERIAL, ELECTRICAL WIRING OR GAS PLUMBING IN THIS AREA.

MAY USE COMBUSTIBLE FACING MATERIAL IN THIS AREA

NON-COMBUSTIBLE FINISH MATERIAL

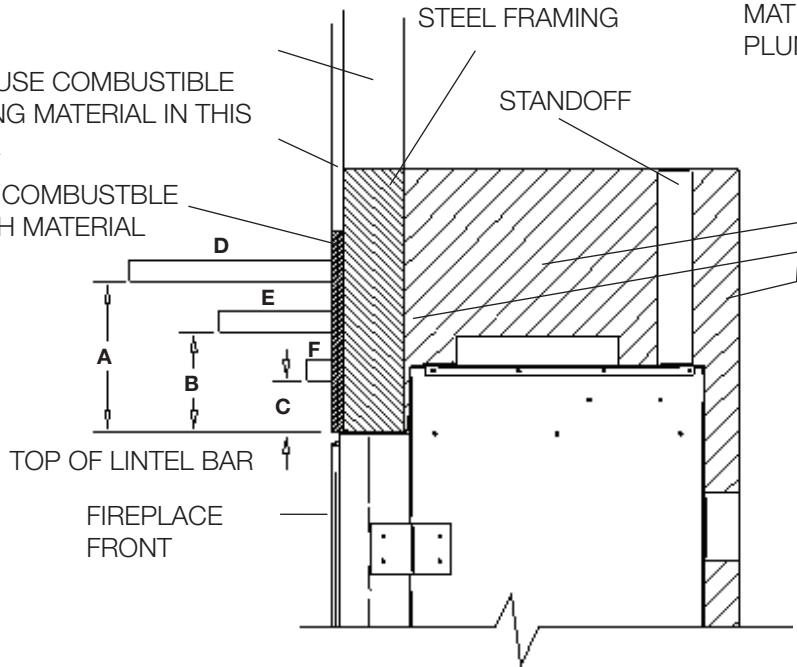

MANTEL CLEARANCE CHART	
* MANTEL CLEARANCE	
A	9"
B	6"
C	3"
** MANTEL DEPTH	
D	12"
E	6 3/4"
F	1 1/2"

Minimum Clearances to Combustibles

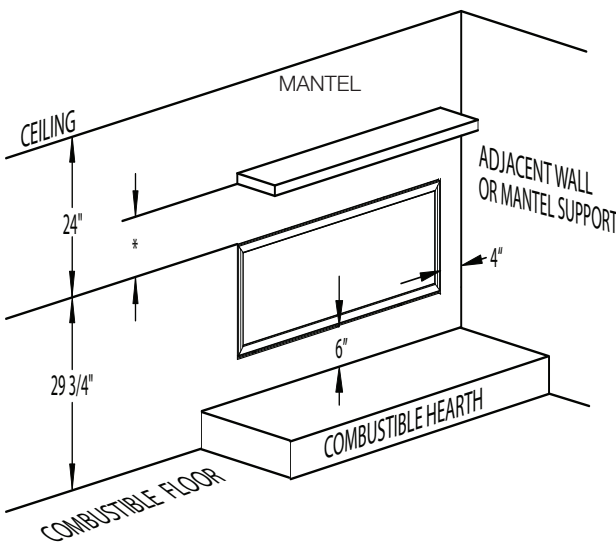

Minimum Clearances:

Side standoffs	0 in. (0 mm)
Back standoffs	0 in. (0 mm)
Top standoffs.....	0 in. (0 mm)
Bottom of appliance	0 in. (0 mm)
Adjacent side wall.....	4 in. (102 mm)
Ceiling to appliance	24 in. (610 mm)
*Mantel to appliance	See mantel clearance chart above
**Maximum Mantel extension.....	See mantel clearance chart above
Mantel support	4 in. (102 mm)
Vertical vent pipe	1 3/4" in.(45 mm)
Horizontal Vent pipe (Top, sides and bottom)....	1 3/4" in.(45 mm)

Unit may be recessed up to 4 1/2" with non-combustible masonry type material

FOR REFERENCE ONLY. CONSULT MANUAL BEFORE INSTALLATION

Steel Stud Framing Kit Dimensions Kit

Minimum Combustible Framing Dimensions

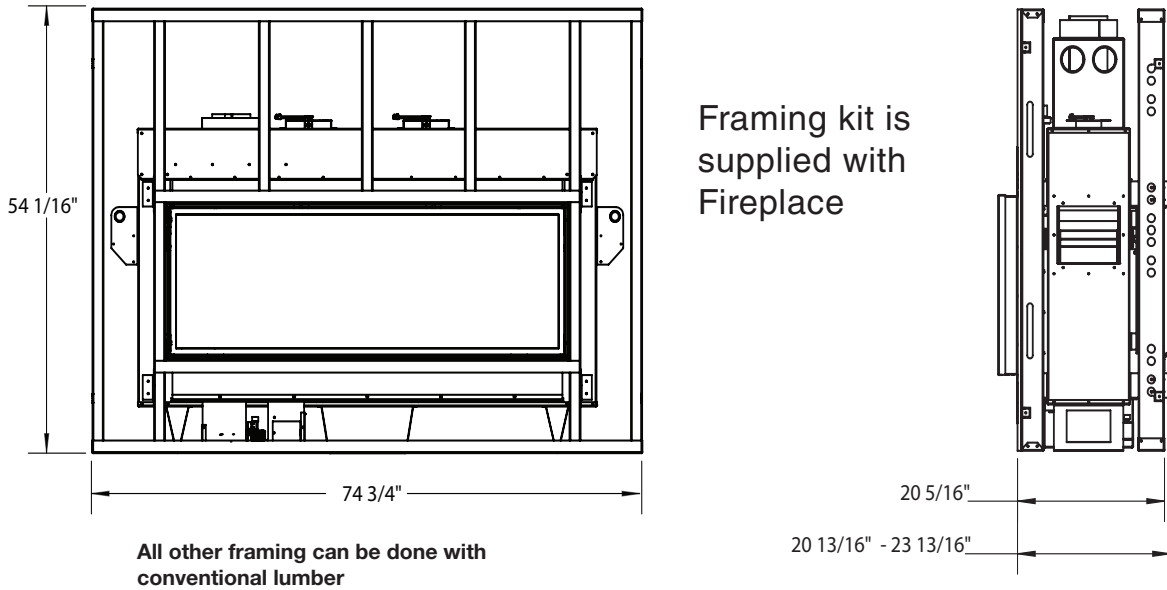

NOTE: Fireplace should be in its final location before framing.

NOTE: Combustible framing must allow for sheetrock installation.

NON-COMBUSTIBLE materials must extend to the top edge and the side edge of the framing kit.

NON-COMBUSTIBLE BOARD NOT INCLUDED.

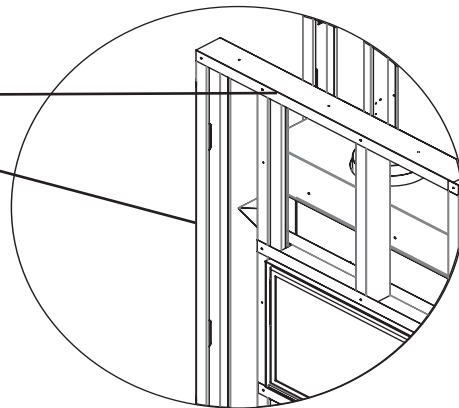

Non-combustible Board Detail

FOR REFERENCE ONLY. CONSULT MANUAL BEFORE INSTALLATION

Proflame 2 Control System

Town and Country D Series fireplaces use the SIT Proflame 2 control system.

This includes an elegant hand-held remote control transmitter with an easy to read LCD display.

The fireplace also comes with a wall-mounted control switch which allows for simple ON/OFF operation, or can be linked with the hand-held remote control unit. This switch has a battery powered back-up system which allows operation during power outages. The wall-mounted switch easily connects to any customer supplied Home Automation System.

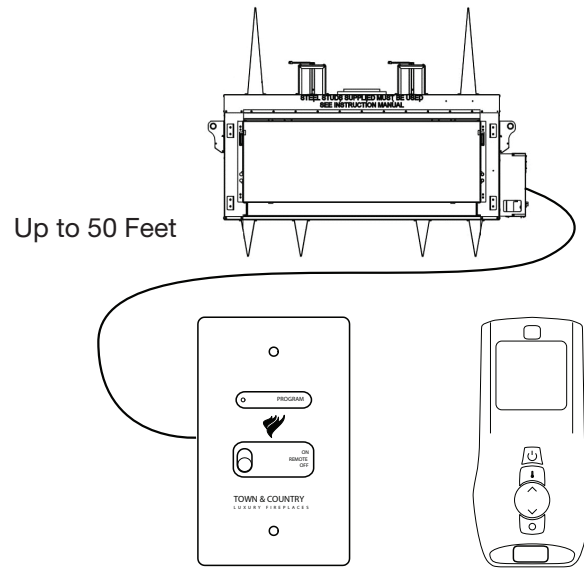

Hearth Extension

Caution: While a hearth extension is not required and combustible flooring materials may be brought directly up to the fireplace, many materials (such as wood flooring) may not tolerate the radiant heat from this fireplace, resulting in discoloration, shrinking and cracking. For this reason, we suggest a non-combustible hearth that is no more than 1" above the bottom of the fireplace. If material is thicker, fireplace must be raised accordingly.

Caution: Hearth extensions thicker than 1" will interfere with the window frame when opening.

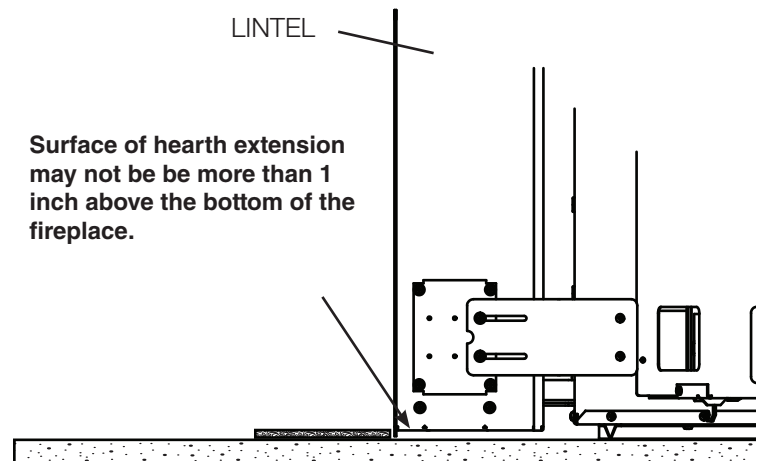

Recessed Installation

Caution: This fireplace may be recessed up to a maximum depth of 4 1/2". This recess must be constructed from non-combustible material. The space between the outside framing edge and the firebox must be completely free of any obstructions or debris, and the window, with trim fitted, must be able to move freely.

No building material is permitted to protrude past the framing edges attached to the fireplace under ANY circumstance.

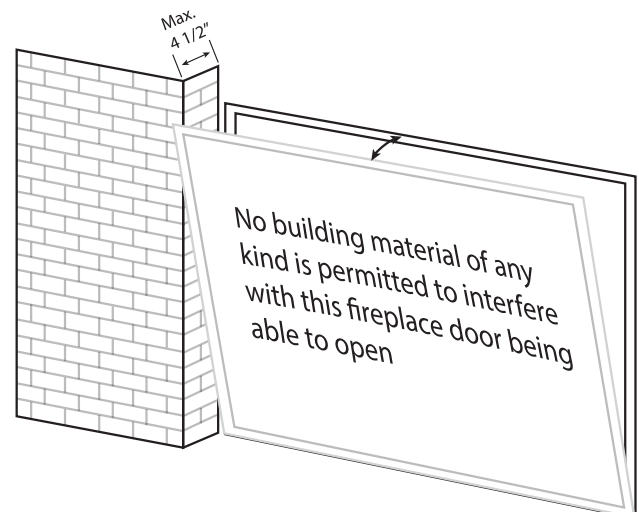

FOR REFERENCE ONLY. CONSULT MANUAL BEFORE INSTALLATION

Power Venting Options

POWER VENTING CONFIGURATIONS

A power vent is mandatory on this indoor/outdoor fireplace. This fireplace can be power vented either horizontally or vertically.

Reach almost any room or commercial setting. Town and Country Power Venting allows runs up to 110' to an outside wall or roof surface (maximum 66' of vertical run). Vent horizontally or vertically with up to six 90-degree elbows, including runs up to 3' below the fireplace.

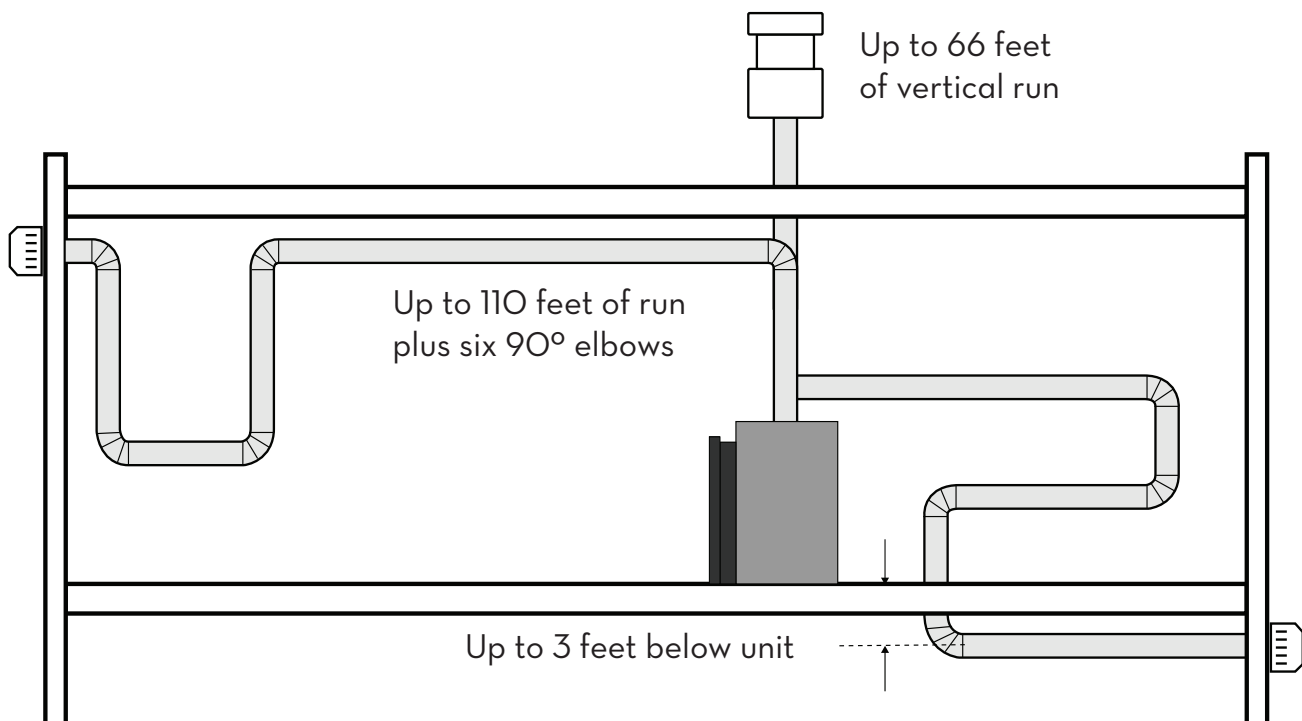

The premium Power Vent fan runs quietly outside, at the exterior terminal.



TCWS54STD Cad Drawing
Available at
www.townandcountryfireplaces.com

Power Vent Terminals

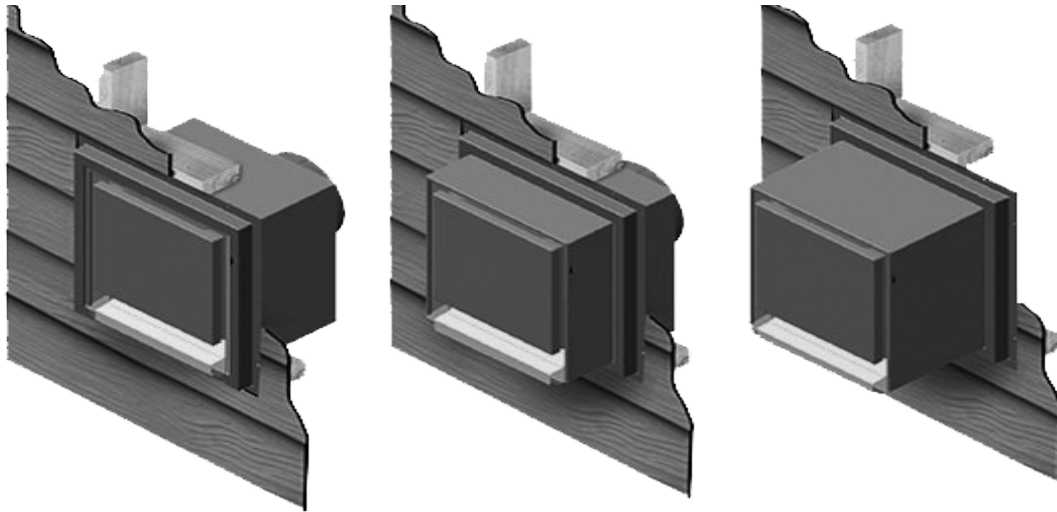

Flush Mount termination

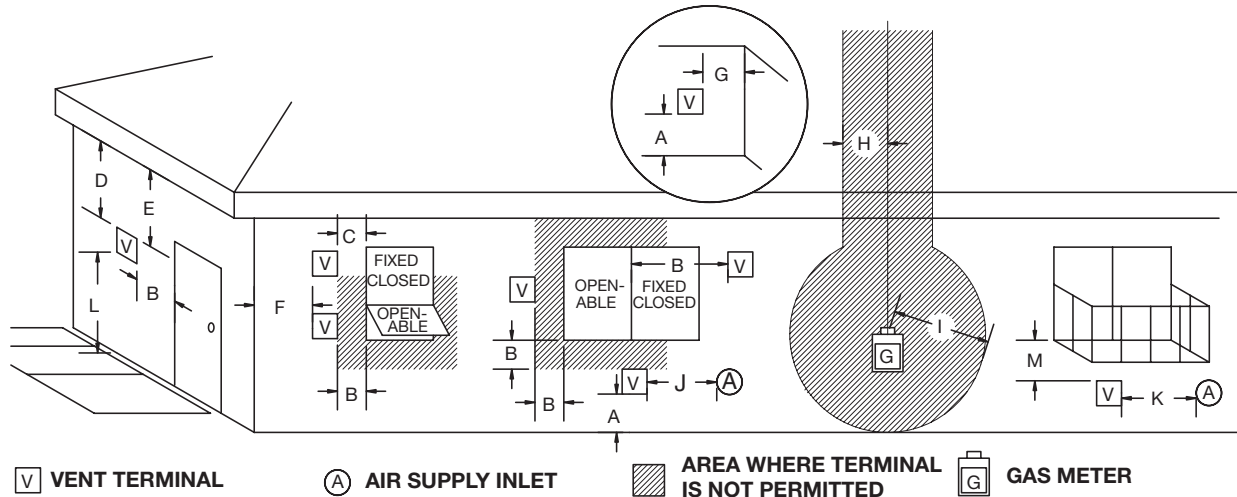

A=	*12 inches (30 cm) min.	Clearances above grade, veranda, porch, deck, or balcony
B=	*12 inches (30 cm) min.	Clearance to window or door that may be opened
C=	12 inches (30 cm) min.	Clearance to permanently closed window recommended to prevent condensation on window
D=	24 inches (60 cm) min.	Vertical clearance to ventilated soffit located above the terminal within a horizontal distance of 2 feet (60 cm) from the edge of the terminal
E=	0 inches (0 cm) min.	Clearance to unventilated soffit
F=	6 inches (15 cm) min.	Clearance to outside corner
G=	3 inches (7.5 cm) min.	Clearance to inside corner
H=	3 feet (90 cm) min.	*Not to be installed above a meter/regulator assembly within 3 feet (90 cm) horizontally from the center-line of the regulator
I=	*6 feet (1.8m) min.	Clearance to service regulator vent outlet
J=	*12 inches (30 cm) min.	Clearance to non mechanical air supply inlet to building or the combustion air inlet to any other appliance
K=	*6 feet (1.8 m) min.	Clearance to a mechanical air supply inlet
L=	*7 feet (2.1 m) min.	^ Clearance above paved side-walk or a paved driveway located on public property

^ a vent shall not terminate directly above a side-walk or paved driveway which is located between two single family dwellings and serves both dwellings*
 ** only permitted if veranda, porch, deck, or balcony is fully open on a minimum of 2 sides beneath the floor*
 * as specified in CGA B149 Installation Codes, Note: local Codes or Regulation may require different clearances
 * for U.S.A. Installations follow the current National Fuel Gas Code, ANSI Z223.1

FOR REFERENCE ONLY. CONSULT MANUAL BEFORE INSTALLATION



Roof Termination



TCWS54STD Cad Drawing
Available at
www.townandcountryfireplaces.com

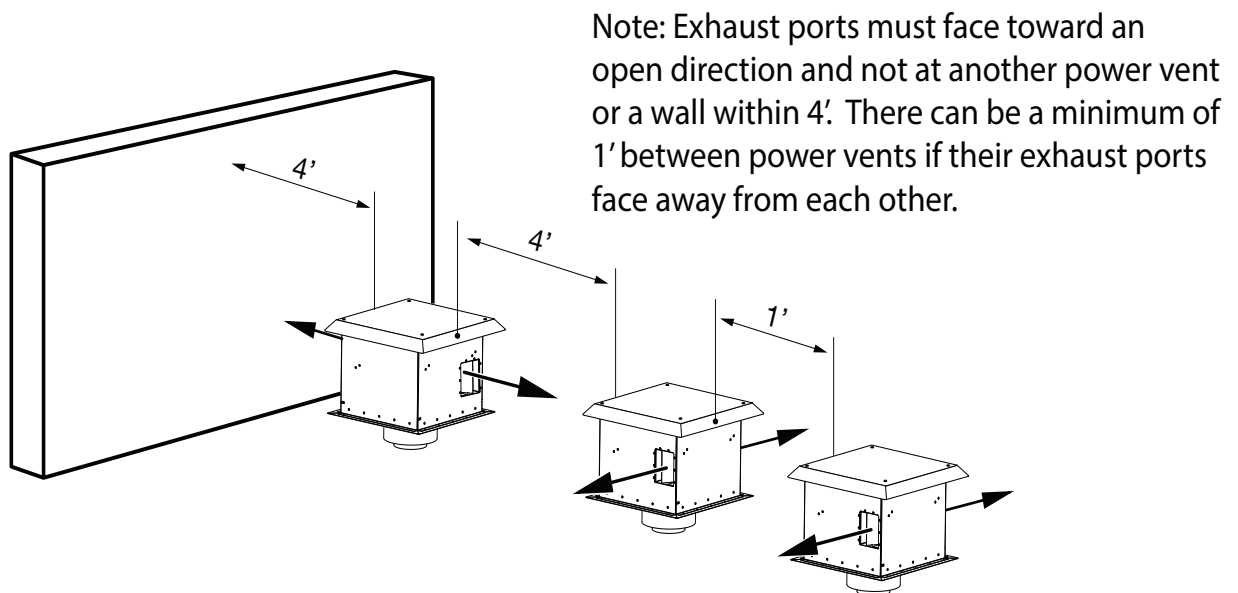

FOR REFERENCE ONLY. CONSULT MANUAL BEFORE INSTALLATION

Reproduction, adaptation, or translation
without prior written permission is prohibited,
except as allowed under the copyright laws.



TOWN & COUNTRY
L U X U R Y F I R E P L A C E S

For personal service pertaining to specific projects, contact:
Town & Country Architect Resource Planner
architects@townandcountryfireplaces.com
www.townandcountryfireplaces.com
Phone: (250) 748-1184
2975 Allenby Road, Duncan, BC Canada V9L 6V8